Guidance v3

Non-Domestic Northern Ireland Renewable Heat Incentive – Guidance

Volume 1: Eligibility and Application Process

August 2019

Contents

Topic	Page
Overview	
Context	
Executive Summary	
1. Introduction	
2. How to Apply	
3. Eligibility Summary & Checklist	
4. General Eligibility Requirements	
5. Technology Specific Criteria	
6. Heat Issues	
7. Metering Eligibility Requirements	
8. Registration for Biomethane Producers	

Appendices

Appendix 1: Meter Placement Examples

Appendix 2: Municipal Waste Lists

Appendix 3: Glossary of RHI Terms

Overview

The Non-Domestic Northern Ireland Renewable Heat Incentive Scheme (NIRHI) came into operation on 1 November 2012 and was suspended to new applicants with effect from 29 February 2016.

The Department of Enterprise, Trade and Investment (DETI)¹ established the NIRHI under Section 113 of the Energy Act 2011 and the Renewable Heat Incentive Scheme Regulations (Northern Ireland) 2012 (“the 2012 Regulations”).

The 2012 Regulations were subsequently amended by:

- the Renewable Heat Incentive Schemes (Amendment) Regulations (Northern Ireland) 2015 (“the 2015 Regulations”);
- The Renewable Heat Incentive Schemes (amendment) Regulations (Northern Ireland) 2016;
- the Renewable Heat Incentive Schemes (Amendment) Regulations (Northern Ireland) 2017 (“the 2017 Regulations”);
- the Northern Ireland (Regional Rates and Energy) Act 2018 (“the 2018 legislation”); and
- the Northern Ireland (Regional Rates and Energy) Act 2019 (“the 2019 legislation”).

This guidance collectively refers to the 2012 Regulations as amended as ‘the Regulations’ but, where necessary, amending legislation has been specifically referenced.

Under Section 115 of the Energy Act 2011, the Gas and Electricity Markets Authority (GEMA) carries out the day to day administration through its office (Ofgem). DfE is responsible for the overarching policy and detailed legislative framework for the NIRHI.

Guidance Document Structure

This volume of the guidance (Volume 1) describes the eligibility requirements of the NIRHI and how prospective installations can become accredited or registered as applicable.

¹ On 8 May 2016, DETI merged with the Department of Employment and Learning to form the Department for the Economy (DfE). References in this guidance to DETI and DfE should be read relevant to the 6 May 2016 transfer.

The guidance is not a definitive legal guide to the NIRHI, although its publication is made in accordance with the Regulations. Prospective participants should familiarise themselves with it and read it in conjunction with the Regulations. In the event of any conflict between the Regulations and the guidance, the Regulations take precedence.

Volume 2 of the guidance sets out the procedures for the administration of the NIRHI under the Regulations. It describes the ongoing requirements for NIRHI participants, information on how periodic support payments are calculated and paid, and Ofgem's / DfE's compliance and enforcement powers.

Associated Documents

The Renewable Heat Incentive Scheme Regulations (Northern Ireland) 2012 have been amended by:

- [Energy Act 2011](#)
- [The Renewable Heat Incentive Scheme Regulations \(Northern Ireland\) 2012](#)
- [Regulation 61 of the Domestic Renewable Heat Incentive Scheme Regulations \(Northern Ireland\) 2014](#)
- [The Renewable Heat Incentive Schemes \(Amendment\) Regulations \(Northern Ireland\) 2015](#)
- [The Renewable Heat Incentive Schemes \(Amendment\) Regulations \(Northern Ireland\) 2016](#)
- [The Renewable Heat Incentive Scheme \(Amendment\) Regulations \(Northern Ireland\) 2017](#)
- [The Northern Ireland \(Regional Rates and Energy\) Act 2018](#)
- [The Northern Ireland \(Regional Rates and Energy\) Act 2019](#)

The [Energy Act 2011](#) supports this publication.

Executive Summary

The Northern Ireland Renewable Heat Incentive (NIRHI) is a financial incentive scheme designed to increase the uptake of renewable heat technologies and reduce Northern Ireland carbon emissions. The scheme provides a subsidy per kWh_{th} of eligible renewable heat generated from accredited installations and pays a subsidy to producers of biomethane for injection into the gas grid.

When the scheme was introduced, DETI appointed Ofgem to administer the NIRHI on their behalf. The Department for the Economy (DfE), previously DETI, is responsible for underpinning NIRHI policy including setting tariffs, establishing the legislative framework, and the introduction of any further phases of the scheme.

Scheme Eligibility

The scheme supports non-domestic renewable heat installations and the production of biomethane for injection. Please note that the Scheme is now suspended to new applications. This guidance is for participants on the non-domestic scheme only. For information on the domestic scheme which was introduced in December 2014, please see the domestic guidance available at [Renewable Heat Incentive for domestic customers | nidirect](#).

The following renewable heat technologies are supported on the non-domestic scheme:

- solid biomass and solid biomass contained in municipal waste
- ground and water source heat pumps
- geothermal
- solar thermal (at capacities of less than 200 kWh_{th})
- biogas combustion (except from landfill gas)
- biomethane injection

Ongoing Obligations

When accredited, scheme participants must comply with a number of ongoing obligations set out in this guidance including regular submission of heat data, meter readings and fuel data for certain bioenergy installations.

Participants must maintain their heating equipment and meters, and report any significant changes to their installation or heat uses to Ofgem. Participants are required to make annual declarations to Ofgem confirming their compliance, and may be selected for audits and/or a site inspection. Failure to comply with ongoing obligations (including notification of a change of ownership of an accredited installation) may lead to compliance action being taken against a participant.

Introduction



Policy Context

- 1.1. The European Union's (EU's) 2009 Renewable Energy Directive² set a binding target that 20 percent of the EU's energy consumption should come from renewable sources by 2020. The UK share of this target commit the UK to increase its use of renewable energy to 15 percent by 2020. Northern Ireland is expected to contribute to the UK's share of the EU target both in terms of renewable electricity and renewable heating.
- 1.2. In September 2010, the NI Executive agreed the Strategic Energy Framework (SEF). The SEF outlined key energy policy areas for Northern Ireland and included four key energy goals:
 - Building competitive markets
 - Ensuring security of supply
 - Enhancing sustainability, and
 - Developing our energy infrastructure.
- 1.3. In order to support the delivery of these four energy goals the NI Executive set a target of 10 percent renewable heat by 2020. The NIRHI is a key policy measure in the delivery of this target.

NIRHI Overview

- 1.4. The NIRHI is a financial incentive scheme designed to increase the uptake of renewable heat and reduce the UK's carbon emissions.

² [2009/28/EC](#)

The scheme provides a subsidy per kWhth of eligible renewable heat generated (subject, where applicable, to tier payments and caps) from accredited installations and by registered producers of biomethane. It aims to encourage the uptake of renewable heat technologies by compensating for barriers to their adoption, including the current higher upfront costs and operational expenditure for these technologies as compared to those using traditional fossil fuels.

- 1.5. A range of renewable heat technologies are supported under the NIRHI including solar thermal, ground and water source heat pumps, biomass and biogas boilers, geothermal, energy from solid biomass in municipal waste and biomethane injection into the gas grid. Payments are made on a quarterly basis over a 20-year period to the owner of the NIRHI installation or producer of biomethane.
- 1.6. DETI introduced the NIRHI in two phases:
 - In the first phase introduced in 2012 , addressed in this guidance document, the NIRHI was opened to parties with eligible installations in non-domestic sectors, and to producers of biomethane
 - The second phase of the scheme extended the scheme to the domestic market from 9 December 2014. This phase is not covered in this Guidance document.
- 1.7. From 18 November 2015, the NIRHI included the introduction of biomass tiering and capping, amendments to the medium and large tariff bands for biomass and relocation in addition to other small changes. The scheme was suspended to new applicants on 29 February 2016. From 1 April 2017 to 31 March 2019 the November 2015 tariff tiering and capping was applied to all small- and medium-sized biomass installations. Details are addressed in this guidance document. From 1 April 2019 a new set of long-term tariffs was applied for all small- and medium-sized installations, as set out in the Northern Ireland (Regional Rates and Energy) (No. 2) Act 2019.

Respective Roles

- 1.8. DfE is responsible for developing NIRHI policy including setting tariffs, establishing the legislative framework, and changes to the scheme. Any queries should now be addressed to DfE.

1.9. Except in the case of certain inspection and enforcement functions, Ofgem administers the NIRHI scheme on behalf of DfE.

1.10. DfE, Ofgem and participants are all involved in making the NIRHI work and each plays a distinct but important role in the scheme. Table 1.1 provides a brief overview of their respective responsibilities.

Table 1.1: Summary of Responsibilities under NIRHI

DfE	<ul style="list-style-type: none"> • Develop overarching policy framework and supporting legislation • Set tariffs for different technologies • Specify detailed eligibility criteria and scheme rules in NIRHI Regulations • Site inspections and compliance
Ofgem	<ul style="list-style-type: none"> • Formally administer the scheme on behalf of DfE and in line with the Regulations and the administrative arrangements • Accredite installations and register biomethane producers as eligible, checking identity, bank details and ownership as part of this process • Make payments to scheme participants
Applicants/Participants	<ul style="list-style-type: none"> • Must comply with ongoing obligations

Ofgem & DfE Key Functions

1.11. The Regulations detail DfEs key functions with respect of the NIRHI.

1.12. Key functions include:

- Ofgem - Accreditation of installations and registration of producers of biomethane which meet the eligibility criteria, including verifying identity, bank details and ownership of an installation
- Ofgem - Making payments on a quarterly basis to participants for the eligible heat output or biomethane injected
- DfE/Ofgem - Monitoring and enforcing compliance with the initial eligibility and ongoing requirements of the NIRHI as outlined in the Regulations
- DfE/Ofgem - Undertaking desk and/or on-site inspections to ensure participants' compliance with ongoing obligations under the NIRHI scheme
- Ofgem - On request by DfE providing information on the progress of the scheme, and

- DfE- Providing a review procedure that allows prospective, current and former participants to challenge DfE's / Ofgem's decisions in relation to the administration of the NIRHI if participants believe decisions are incorrect.

1.13. DfE and Ofgem will carry out these functions as efficiently and effectively as possible within the scope of the powers as laid down in the Regulations and Section 114 of the Energy Act 2011.

Publication of tariffs

1.14. DfE will publish an adjusted tariff table on an annual basis to reflect changes in the relevant inflation measure (Retail Prices Index (RPI) or Consumer Price Index (CPI)). This will be published on or before 1 April each year for the period commencing 1 April of that year and ending 31 March the following year.

1.15. Please see the [NI Direct website](#) for the most up-to-date tariff table.

Reporting

1.16. DfE will publish information in respect of the following matters:

- aggregated details of accredited installations and fuel type
- aggregated details of the technology replaced
- total amount of periodic support payments made in that reporting period
- total amount of heat generated for which payments have been made under the NIRHI
- sustainability information for certain installations using biomethane
- volume of biomethane injected by registered biomethane producers

1.17. DfE may also publish the following aggregated information on an ongoing basis:

- the number of accredited NIRHI installations and registered biomethane producers
- the technology and installed capacity of the installations
- the total amount of heat generated and biomethane produced together with the total amount of periodic support payments made under each tariff

Queries

1.18. Any queries relating to the scheme operation or applicant eligibility should be emailed to rhi.enquiry@ofgem.gov.uk with the nature of the query clearly marked. If you are an existing participant, please note in the query that you are a participant and provide your installation number. For telephone enquiries, the team can be contacted on 0300 003 2289. The phone line is open Monday to Friday except public holidays. Please check the Ofgem NIRHI website for the opening hours of the phone line³.

Scope of this Guidance

1.19. This guidance cannot anticipate every situation which may arise. Where an issue arises which is not addressed in this guidance, DfE/Ofgem will adopt an approach which they consider to be consistent with the Regulations. Any additional guidance will be published on DfE's and/or Ofgem's website.

1.20. This guidance is not intended to provide comprehensive legal advice on how the Regulations should be interpreted or itself to have legal effect. At all times, the onus is on the owner of an installation or producer of biomethane to ensure that they are aware of the requirements of the Regulations.

1.21. This guidance describes Ofgem's and DfE's approach to matters concerning its general administration of the scheme in accordance with the current Regulations. If the Regulations change, Ofgem and DfE will review and revise the guidance as necessary.

1.22. Where a participant contracts with third parties in relation to the generation of renewable heat or the production of biomethane, it is the participant's responsibility to ensure, via contractual or other arrangements that these parties comply with any relevant ongoing obligations under the NIRHI scheme. The obligations entered into on becoming accredited or registered remain those of the participant rather than being transferred to the third party concerned.

³ <https://www.nidirect.gov.uk/contacts/contacts-az/renewable-heat-incentive-enquiry-line>

Territorial Applicability

1.23. In accordance with the Act, we can only make payments to eligible renewable heat installations that are generating heat in Northern Ireland or to biomethane producers injecting into the grid in this region.

Treatment of Personal Data

1.24. All personal data collected from participants by Ofgem will be processed in accordance with Data Protection law. Ofgem is a public Authority and must protect the public funds they handle, so they may use the information you have given them to prevent and detect fraud. As part of this process, your information may be supplied to a third party that conducts ID verification and bank account validity checks and contractors undertaking inspections. They may also share this information, for the same reasons with other government organisations involved in the prevention and detection of crime. Please note that some personal data will be shared by Ofgem with DfE for the purpose of monitoring the scheme. It may also be necessary for DfE to share personal information with other government organisations to assist with the monitoring of the Scheme.

The Northern Ireland Non-Domestic RHI Scheme is currently suspended for new applications. This section provides information which is relevant for past applications. As such, some of the information may no longer be relevant but is included here for reference purposes. Should the Scheme re-open in the future, DfE and Ofgem will revise and reissue this guidance.

How to apply

2

Chapter Summary

This chapter sets out what accreditation under the NIRHI means, who can apply, what the process is for applying to the scheme, and how to determine how many applications you need to complete. The registration process for biomethane producers is addressed separately in Chapter Eight of this volume.

Figure 1: High level end to end process for an NIRHI participant

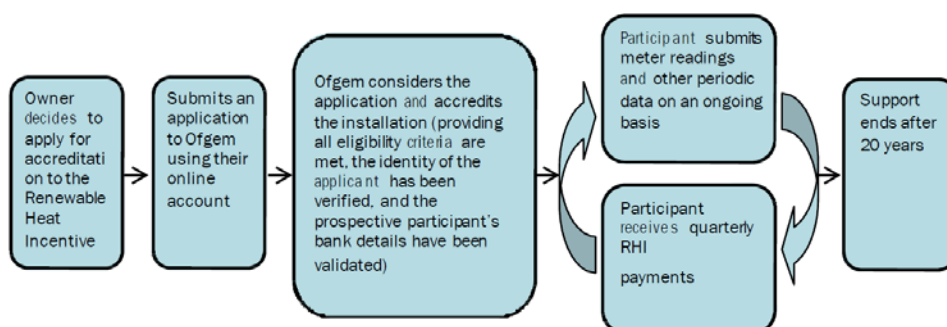

Accreditation under the Northern Ireland Renewable Heat Incentive

Overview

2.1 In order to receive support under the NIRHI, an eligible installation will have to be accredited by Ofgem. Accreditation (which is defined in the Regulations) is the term used to denote admission by Ofgem of an installation to the scheme once it is determined that the installation meets the eligibility criteria and that the application for accreditation is properly made.

2.2 Biomethane producers are subject to different requirements. For full details on how to register as a biomethane producer for the NIRHI, please see Chapter Eight, 'Registration for Biomethane Producers'.

2.3 In order to gain accreditation for an installation, an applicant will have to demonstrate to Ofgem that an installation meets the NIRHI eligibility criteria, which are explained throughout this document.

2.4 Applications for NIRHI accreditation can only be made by an Authorised Signatory. An Authorised Signatory is a person who is authorised to open and use an account with the Ofgem NIRHI website or provide information by post, submit reporting information and complete the NIRHI annual declaration. If the applicant is not an organisation this person must, as appropriate, be the owner of a renewable heat installation (or in the case of an installation which has multiple owners, the representative owner who has authority to act on behalf of all such owners) or where the owner or representative owner is an organisation, the nominated individual who is authorised by the organisation to open and use an account with the Ofgem NIRHI website or submit postal information on behalf of that organisation in its capacity as an owner or representative owner.

2.5 Prior to accreditation, Ofgem must successfully verify the identity of the Authorised Signatory using personal information provided to them, and also validate the bank details provided. This information will be treated in accordance with the Data Protection Act as highlighted in Chapter One. Their obligation to verify the identity of applicants and validate bank details is set out in the Regulations and is part of a package of fraud prevention measures designed to guard against the misappropriation of public funds.

2.6. For a quick reference eligibility summary and checklist, please see Chapter Three. For more detailed information on the general eligibility requirements, the requirements for individual technologies, heat uses and metering eligibility requirements, please see Chapters Four to Seven.

Before you apply

2.7 Applicants are likely to improve their understanding of the application process and provide the relevant information in support of their application if they:

- Read this guidance in full. It provides detailed information on Ofgem’s approach to administering the scheme, eligibility requirements and information on areas of interpretation.
- Prepare your accreditation application well. Gather relevant information (e.g. technical specifications of meters and boilers, schematics, planning consents, invoices and commissioning documents) that you will need to provide. You have the option of sending these in electronically as part of your online application, and it is recommended that you send the information in this way. This guidance provides information on the types of information Ofgem will need applicants to provide.
- Send a high quality application. One cause of operational delays in assessing electronic applications is resolving issues with poor quality submissions. Ofgem recommend you provide clear, concise and complete information and ensure electronic documents are high quality (e.g. easy to navigate, any scans are legible).

Making an application

Figure 2: How to apply for accreditation

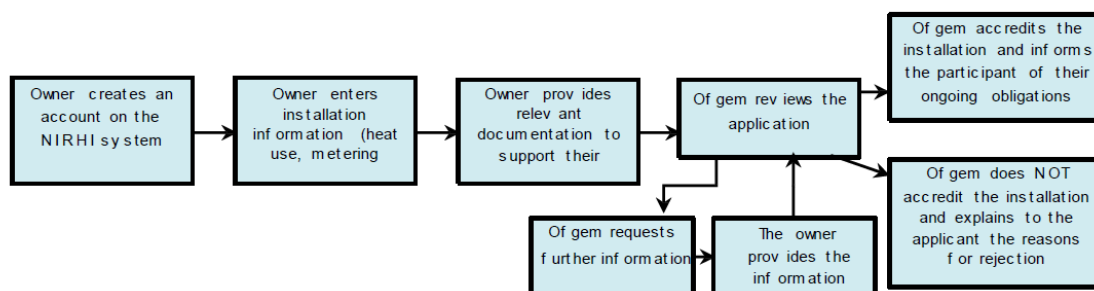

2.8 To apply for accreditation for an installation, you will need to apply online via the Ofgem NIRHI website (www.ofgem.gov.uk/NIRHI), and send in a separate hard copy form with your organisation’s bank account details. If you are unable to apply online you will be able to call Ofgem on 0845 200 2122 to discuss your requirements, which may include the provision of a paper application. Please note that Ofgem recommend applicants apply via the online system as this will allow Ofgem to process your application more quickly.

2.9 Accreditation can only be received once an eligible installation has been commissioned. For certain installations there is the provision for preliminary

accreditation where an installation has not yet been commissioned. Please see the 'Preliminary accreditation' section below.

2.10 When completing the NIRHI application process online, please be aware that all accreditation questions relevant to your installation will need to be answered before you can submit your application. The information you will be required to provide at the application stage will depend on the technology type and size of your installation, and the complexity of your heat uses.

2.11 You will need to provide evidence in support of your application that shows the installation company details, date of installation and installation serial number for your installation. Because each application will be different, this evidence could be any one (or a combination) of the following:

- Receipts and/or invoices relating to the installation of the equipment.
- Commissioning certificate.
- Commissioning report.
- Photograph of the installation clearly showing the serial number of the equipment.
- Photographs of the heat meters.

2.12 Also, to receive accreditation, you must declare at this stage that you (or the owner(s) you represent) will continue to meet the ongoing obligations. For further information on these obligations, please see Volume Two.

2.13 You must ensure that the information you submit is accurate. If Ofgem subsequently finds that accreditation information was incorrect they may take compliance action. Receiving a financial gain through knowingly submitting false information could constitute fraud and where they suspect this has happened they will pass information on to the relevant authorities for further action which may lead to prosecution.

Requests from Ofgem for further information

2.14 Once you have submitted your application and your identity and bank details have been verified, Ofgem will then review all the information before making a decision as to whether the installation can be accredited. In some cases, they will need to contact you for further information to enable them to verify eligibility. After submitting your application you should therefore check for follow-up communication from Ofgem. Once they have received all of the necessary information, they will review your application for accreditation.

2.15 Please note that you must submit all information that directly relates to your installation via the NIRHI IT system. This will help to ensure data integrity, a proper audit trail, and minimise the time taken to process your application. N.B. The bank account information form is an exception to this as it must be printed, completed and

posted to Ofgem. There could be other exceptional circumstances when you may be asked to provide data or documents via email or post.

2.16 If Ofgem is satisfied that the application has been properly made, that all of the relevant eligibility criteria have been met and that you are able to comply with the ongoing obligations of the scheme, they will then accredit the installation and you will become a participant in the scheme. Ofgem will notify you in writing whether your application for accreditation has been successful.

2.17 Please also note that before your installation is accredited, Ofgem may arrange for a site inspection to be carried out so that they can be assured that the installation is eligible and should be accredited.

2.18 Participants are required to retain evidence relating to the installation's design and installation, such as technical calculations, drawings, commissioning data or other operating and maintenance documentation, as applicable to the installation. Ofgem may ask to see this during the accreditation process or as part of an audit.

2.19 Once you are a participant in the scheme, you are able to receive support for your accredited installation. Ofgem will send you a statement of eligibility which will include or refer you to the following:

- the date of accreditation
- the applicable tariff rate for your installation
- the process and timing for providing meter readings
- details of the frequency and timetable for payments
- the tariff lifetime and the tariff end date for the installation
- the terms and conditions for your ongoing participation in the scheme.

2.20 If your application is not successful, you will be notified in writing of the reason(s) why. You are entitled to ask for a review of the decision to reject an application for accreditation. For more information on how to request a review, please see Chapter Twelve, Volume Two.

2.21 A condition of accreditation is that you must notify Ofgem within 28 days of any changes to your accredited installation or to any of the plants, including the installation of another plant, supplying heat to a heating system of which your accredited installation forms part. You must contact them with this information, and, depending on the information that has changed, amend your details in your online account. If the new information you supply affects your tariff rate or your eligibility to receive NIRHI payments they shall notify you and advise you as to what they intend to do in the circumstances.

Date of accreditation

2.22 The date of accreditation for your installation is the date from which your RHI payments will be calculated. If your application is successful, the date of accreditation will be the first date on which all three of the following requirements are satisfied:

- the application is ‘properly made’ in accordance with regulation 22(2) and (3) of the Regulations (including your supplying us with any information and/or documents relating to your application we have requested you supply);
- all RHI eligibility requirements applicable to the installation are satisfied; and
- the installation has been commissioned. To ensure that the processing of your application can be completed in a timely manner, a hard copy of your bank details should be sent to us as soon as possible after you have completed your online application.

2.23 If in exceptional circumstances you are submitting a paper application, the same criteria as set out above will apply to determine whether your application is successful. We recommend that proof of posting/delivery should be obtained when submitting postal applications.

All technologies, excluding producers of biomethane:

2.24 It is important to note that the applicable tariff and the date that RHI payments are calculated from is the later of:

- (a) the first day on or after we receive your application on which both the application was “properly made” and the eligibility criteria were met, and
- (b) the date your installation was commissioned.

2.25 A ‘properly made’ application must include all information we ask for in the application form to a suitable standard, to enable us to make a decision on the eligibility of your installation.

2.26 If you just submit an application on a particular and the application is not ‘properly made’ (or the installation is not eligible or commissioned prior to this), you are not entitled to a tariff or RHI payments from this date. Your applicable tariff and entitlement to payments will only date from the time the application becomes ‘properly made’ – which is the date all outstanding information that is required has been provided and we are satisfied your installation is eligible for the scheme (if the installation was commissioned before then). Therefore it is in your interest to ensure that your application provides all the necessary information when you submit it, or that any outstanding information required is submitted to us as soon as possible.

Producers of biomethane only

2.27 For producers of biomethane, the ‘date of registration’ is the first day on or after we receive your application on which the application was ‘properly made’. A ‘properly made’ application must include all information we ask for in the application form to a

suitable standard, to enable us to make a decision on the eligibility of your installation.

What is the difference between the 'installation' and 'commissioning' of an eligible installation?

2.28 To install an eligible installation means to build and/or put in place the relevant plant. At this stage, the plant has not begun generating heat. To 'commission' a plant means to carry out all necessary tests and procedures required by industry standards to show that the plant is able to deliver heat for the purpose for which it was installed. For smaller scale installations, installation and commissioning may happen on the same day. At the larger scale there is usually a significant testing period, so the date of installation and date of commissioning may be different.

How to apply when you have multiple plants

2.29 Applicants should apply only once for each installation for which they wish to claim NIRHI support. If you have multiple plants then you need to know whether these need to be applied for separately or if they should be considered together as a single installation.

2.30 As provided in the Regulations⁴, an installation can consist only of one plant unless two or more plants making up an installation meet the following criteria:

- the component plant meets the eligibility criteria
- the plants use the same source of energy and technology (eg ground source heat pump)
- the plants form part of a common heating system, and
- none of the plants has already been accredited as an NIRHI installation.

2.31 In these cases, two or more component plants will be regarded as a single plant for NIRHI purposes if, in addition, the eligibility criteria referred to in the Regulations⁵ are also satisfied and you should make one application for that single plant.

2.32 For example, if you wanted to apply for NIRHI support for two biomass boilers supplying heat to a common heating system, these would be treated as a single plant if the other conditions mentioned above were also satisfied and your installation would comprise both biomass boilers. You would submit a single application including information on both boilers, rather than submitting two separate applications.

2.33 If your plants do not use the same source of energy or form part of different heating systems, or if the other conditions referred to above are not met, they will be

⁴ Regulations, Part 2, Chapter 2, Regulation 14(2) & (3)

⁵ Regulations, Part 2, Chapter 2, Regulation 14(3)

considered to be standalone not component plants and, therefore, will be treated as separate installations. You will have to apply for accreditation for each installation (plant) separately in this instance. Separate metering arrangements will also apply.

2.34 Please see Figure 3 to assess whether you should submit a single or multiple applications for NIRHI support.

2.35 Where an installation comprises more than one component plant (ie forms a single plant) Ofgem will consider the *combined installation capacity* of the component plants when determining the appropriate eligibility criteria for the installation. For example, the independent report on metering arrangements (see Chapter Seven of this Volume for further information on the report) would be required if the combined installation capacity of both boilers as discussed in Section 'Installation Capacity' of Chapter Four is equal to or greater than 1MWth.

2.36 If one or more of the plants is already accredited under the NIRHI, the addition of a further plant may be treated as 'additional capacity.' Please refer to Volume Two, Chapter Seven, 'Treatment of additional capacity' for further information on how to apply for accreditation for the additional plant(s).

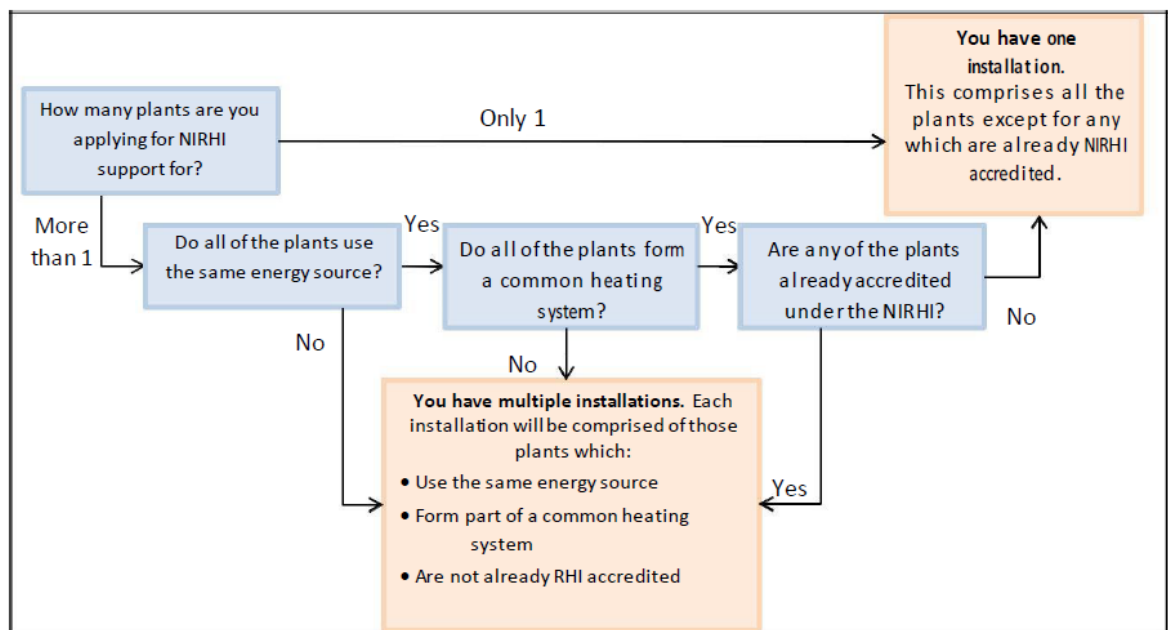

Figure 3: Do I need to submit a single application for NIRHI support or multiple applications?

Inspections and access to third party premises

2.37 In order to encourage compliance with the scheme, Ofgem (or agents authorised on their behalf), will carry out a programme of site inspections of plants at the pre-accreditation stage and of accredited installations on an ongoing basis.

2.38 In instances where the installation and/or its associated infrastructure are located on third party premises not owned or controlled by the participant, the participant will be required, as a condition of accreditation, to ensure access (by contractual or other means) for Ofgem (or their authorised agents) to such premises for the purposes of inspection. This will include access to premises which are served by the installation for the purpose of verifying eligible heat use. They may also require you to provide evidence (eg site plans for domestic premises or external photographs) that domestic premises receiving heat from the heat distribution system are in fact domestic and do not have ineligible uses.

2.39 Further information regarding Ofgem's approach to the audit and inspection of accredited installations can be found in Chapter Eleven, Volume Two.

Preliminary Accreditation

2.40 In certain cases, applicants who are proposing to construct or operate an installation can apply for preliminary accreditation. DETI has decided to allow preliminary accreditation for certain proposed installations at the planning stage to give relevant applicants more certainty about future accreditation.

What does preliminary accreditation mean?

2.41 Preliminary accreditation means an individual or an organisation can submit plans and evidence demonstrating that once built, an installation would meet the eligibility criteria of the NIRHI scheme. If they are satisfied that the eligibility criteria would be met, that it is likely renewable heat will be generated at the plant and that certain planning requirements are met, Ofgem will grant preliminary accreditation, which may include conditions. It is only available for installations that have not yet been commissioned.

2.42 Receiving preliminary accreditation can be considered as a form of 'in principle' agreement. It does not itself make the applicant a participant on the scheme, and no payments will be made on the basis of a preliminary accreditation. But it does give assurance that once the proposed installation is built and the owner applies for 'full' accreditation to the scheme, they will grant full accreditation providing that the installation is then built in line with the plans submitted, and other conditions are met as set out below.

2.43 There are no time limits on the validity of preliminary accreditation. However, receipt of preliminary accreditation is not a guarantee that a future full accreditation application will be granted. In certain circumstances specified in the Regulations Ofgem will not do so, including where the legislation has changed since the preliminary accreditation in a way that means that, if the application for preliminary accreditation had been made after the change, it would have been refused. Similarly,

Preliminary accreditation does not guarantee that a specific tariff rate will be received if future regulation changes affect tariff rates.

Who is eligible for preliminary accreditation?

2.44 Preliminary accreditation is for larger, more complex and bespoke installations, where greater up front clarity on eligibility may be needed. The Regulations only allow applications for preliminary accreditation for the following technologies:

- geothermal
- biogas
- solid biomass and solid biomass contained in municipal waste installations – but note this is only available for those proposed installations with a capacity of 200kWth and above.

2.45 As stated in the Regulations⁶, you will be required to provide evidence that relevant planning requirements relating to the construction or operation of an installation are satisfied when applying for preliminary accreditation. This means that an installation has been granted the necessary planning permission, or that such planning permission is not required and appropriate evidence of this is provided.

2.46 Where planning permission is conditional, it should be accompanied by an explanation of why it is conditional. Ofgem may, upon application by the person who proposes to construct or operate the installation, grant preliminary accreditation. They cannot grant preliminary accreditation unless the consent or permission is forthcoming or it is evidenced that consent or permission is not needed. Given time limits on planning consents and permissions, they will only grant preliminary accreditation if the consent or permission is current.

Metering requirements

2.47 As part of your preliminary accreditation application, you will be required to submit a schematic diagram detailing the proposed layout of your installation including positioning and the number of meter(s) that will be used. Please see section 'Schematic diagram' in Chapter Seven for further information on this requirement. Please note you are not required at this stage to provide information regarding meter serial number(s), make(s) or model(s) of your meter(s), where these have not yet been selected. You will be required to provide an updated schematic with the full details if you later apply for full accreditation.

Administration of preliminary accreditation

⁶ Regulations, Part 3, Regulation 26(1)

2.48 All applicants who receive preliminary accreditation for an installation will be required to advise Ofgem of any material changes made to the installation. 'Material changes' means changes to the installation as planned or built which may affect the tariff of the installation under the NIRHI, or that would mean that the installation would no longer be considered eligible to receive full accreditation under the NIRHI. Applicants should contact Ofgem for advice if they are in any doubt as to whether the changes they are considering are material.

2.49 Please note that the requirement in relation to grants from public funds or other public support (discussed in the 'NIRHI interaction with publicly funded grants and other public support' section in Chapter Four) also applies to applicants for and recipients of preliminary accreditation. If you are awarded preliminary accreditation and are subsequently paid a grant from public funds for the costs of purchasing or installing the equipment, Ofgem will not be able to grant full accreditation. For further information on the publicly funded grants requirement, see section 'NIRHI interaction with publicly funded grants' in Chapter Four.

2.50 Ofgem may attach other conditions upon granting preliminary accreditation to an applicant. These will depend on the circumstances of the application and will be determined on a case by case basis.

Notification of preliminary accreditation

2.51 Ofgem will confirm preliminary accreditation in writing to the applicant. Preliminary accreditation will in most cases be effective from the date they issue the notification letter to you or in some circumstances a later date they may specify in the notice. The notification letter will also specify any conditions attached to the preliminary accreditation.

2.52 Alternatively they may contact applicants to specify what further information is needed before preliminary accreditation can be granted.

2.53 If they decide to reject an application, they will write to you with an explanation of the reasons why.

Circumstances under which preliminary accreditation conditions may be attached, amended, or withdrawn

2.54 The Regulations set out circumstances in which, following the granting of preliminary accreditation, conditions may be attached to a preliminary accreditation, conditions attached to a granted preliminary accreditation can be amended, or a preliminary accreditation can be withdrawn. These circumstances are the following:

- there has been a material change(s) in circumstances since the preliminary accreditation was granted;
- the information contained in the original application was incorrect in a material respect; or
- there has been a change in the applicable legislation since the date of preliminary accreditation was granted, and that change is such that if the application for preliminary accreditation had been made after this change the preliminary accreditation would not have been granted; or
- any conditions attached at the date of granting preliminary accreditation have not been complied with.

Conversion to full accreditation

2.55 Once an installation in receipt of preliminary accreditation has been built, the owner of the installation can apply for full accreditation in order to become a participant in the NIRHI and receive NIRHI payments. As part of their application for full accreditation the applicant should give the reference number of the preliminary accreditation that had been received.

2.56 Where the installation has been built and commissioned in line with the original preliminary accreditation, preliminary accreditation has not been withdrawn and any conditions (including amended or additional conditions) set out in the preliminary accreditation continue to be complied with, Ofgem will grant full accreditation unless:

- they consider the information on which the original preliminary accreditation was based was incorrect in a material respect such that, if they had known about it at the time of preliminary accreditation, they would not have granted the preliminary accreditation, or
- there has been a material change in circumstances or a change in applicable legislation since the date of preliminary accreditation such that, in either case, if the application for preliminary accreditation had been made after the date of the change it would have been refused.

The Northern Ireland Non-Domestic RHI Scheme is currently suspended for new applications. This section provides information which is relevant for past applications. As such, some of the information may no longer be relevant but is included here for reference purposes. Should the Scheme re-open in the future, DfE and Ofgem will revise and reissue this guidance.

Eligibility summary and checklist



Chapter Summary

This chapter contains a summary of the key eligibility criteria along with references for each item as to where else in the document a more detailed explanation can be found. It should be read in conjunction with the following chapters.

Eligibility Criteria

3.1 If you want to apply for NIRHI accreditation for an installation, you will need to demonstrate to Ofgem that the installation meets the eligibility criteria for the scheme.

3.2 Please note that producers of biomethane should refer to Chapter Eight, 'Registration for biomethane producers' for the specific requirements for biomethane producers.

Overall eligibility checklist

3.3 The following checklists summarise for ease of reference the key eligibility requirements – this is meant as a starting point and should not be seen as comprehensive or as an alternative to reading the detailed requirements in this document and in the Regulations.

Table 1: General eligibility checklist

<p>1) The applicant is the owner of the eligible installation (see Chapter Four), the owner's identity has been verified by us and their bank details have been validated.</p> <p><i>Where there are multiple owners, the applicant must have permission to act for the others</i></p> <p>2) The plant is an eligible renewable heat technology type and size (please see Table 2 below).</p> <p>3) The installation was completed and the plant was first commissioned on or after 1st September 2010 (see Chapter Four).</p> <p><i>(Or is a CHP installation which was generating electricity only prior to 1st September 2010 using biomass or biogas and converted to become an eligible CHP system on or after 1st September 2010).</i></p> <p>4) No grants from public funding have been or will be received for purchasing or installing the eligible installation, or where such a grant has been made it has been repaid in full to the persons or authority who made it (see Chapter Four).</p> <p><i>(or for installations commissioned between 1st September 2010 and the start date for the RHI those grants have been repaid).</i></p> <p>5) The plant was new at the time of installation (see Chapter Four).</p> <p>6) For applicable technologies: The plant has MCS or equivalent certification, and the installer of the plant had MCS or equivalent certification at time of installation (see Chapter Four).</p> <p>7) The plant uses either liquid or steam as the heat delivery medium (see Chapter Four).</p> <p>8) The plant is providing heat for at least one eligible heat use: heating a space, heating water or carrying out a process, where the heat is used within a building, or for cleaning or drying carried out on a commercial basis otherwise than in a building (see Chapter Five).</p> <p>9) The installation is not solely heating a single domestic premises (see Chapter Four).</p> <p>10) The metering arrangements are correct – right types of meters, calibrated, and placed in correct locations according to whether the installation is classed as 'simple' or 'complex' (see Chapter Seven).</p> <p>11) The specific criteria, relevant to the technology applied for are met (see table 2 and Chapter Five).</p>
--

Eligible technologies and sizes

Table 2: Eligible technologies and sizes and technology specific criteria

Eligible technology	Technology-specific criteria
Solid biomass	All scales eligible apart from 1MWth and above
	MCS certification requirements apply for installations less than or equal to 45kWth
	Must be specifically designed and installed to use solid biomass as its
	only primary fuel source
	Fuel eligibility requirements (see Volume Two)
Solid biomass contained in municipal waste	All scales eligible apart from 1MWth and above
	May not burn non municipal waste
	Fuel eligibility requirements (see Volume Two)

Ground-source heat pumps Water-source heat pumps	All scales eligible
	MCS certification requirements apply for installations less than or equal to 45kWth
	Must extract naturally occurring energy
	Must have a CoP of at least 2.9
	Reversible heat pumps must only measure heating not cooling
	Capacity of heat pumps to be specified based on design conditions
Geothermal	All scales eligible To count as geothermal, must generate heat using naturally occurring energy located and extracted from at least 500m beneath the surface of solid earth
Solar thermal	Installations less than 200 kWth eligible
	MCS certification requirements apply for installations less than or equal to 45kWth
	Collector type must be flat plate or evacuated tube
Biogas combustion	Installations less than 200 kWth eligible
	Must be from anaerobic digestion, gasification or pyrolysis
	Anaerobic digestion stations that are accredited under the NIRO are not eligible for RHI support.
	Participant must not use biogas which is landfill gas
	May not generate heat from solid biomass
	Fuel eligibility requirements (see Volume Two)
CHP	Must be one of the following technologies: geothermal, biogas, solid biomass contained in municipal waste, or solid biomass, and meet the criteria for those technologies
	Ineligible if accredited under the NIRO before 1 October 2015.
Biomethane injection	See Chapter Eight

The Northern Ireland Non-Domestic RHI Scheme is currently suspended for new applications. This section provides information which would have been relevant for past applications. As such, some of the information may be no longer be relevant but is included here for reference purposes. Should the Scheme re-open in the future, DfE and Ofgem will revise and reissue this guidance.

Please note, supplementary information on the treatment of grants from public funds and other public support under the Northern Ireland Renewable Heat Incentive has been published on the Department for the Economy's website accessible at:

<https://www.economy-ni.gov.uk/publications/factsheet-grants-and-other-public-support-and-state-aid>

General eligibility requirements

4

Chapter Summary

This chapter sets out the general eligibility criteria for accreditation under the NIRHI. This chapter also discusses the requirements for transitional combined heat and power (CHP) installations. Please see the Chapter Five for details on the requirements for individual technologies.

4.1 The following sections set out a number of general eligibility criteria that apply to all applications.

The owner of the installation must be the applicant

4.2 It is a requirement that the owner, or where more than one person is the owner, one of the owners (the 'representative owner'⁷) as agreed with the other owners, of an installation be the person making the application for accreditation. An 'owner' in the context of the NIRHI is the person/organisation with exclusive rights and liabilities in respect of an NIRHI installation. The owner or where there is more than one owner, the representative owner, is the person who will receive NIRHI payments for an accredited installation. Ofgem expect that the owner will normally be the person/organisation who purchased and paid for the installation of the equipment.

4.3 The only exception to the above is in the circumstance of a 'hire purchase agreement, a conditional sale agreement or any agreement of a similar nature'. In these cases, the Act⁸ defines the 'owner' for NIRHI purposes to be the person in possession of the plant under such an agreement. So it is this person who should apply for the NIRHI. Ofgem may require evidence from the applicant to verify that such an agreement is in place. Ofgem will interpret 'any agreement of a similar nature,' to mean a contract providing for the separation of legal ownership and physical possession, and containing provision (which may be subject to conditions) for the ultimate transfer of ownership to the person having possession.

4.4 As part of the application for accreditation, the applicant will be required to declare that they are the owner, or representative owner, of the relevant eligible installation.

4.5 Where the prospective participant is a company or public authority, an individual within that organisation should be nominated by the owner or representative owner to act on the organisation's behalf when applying for accreditation under the NIRHI ('nominated individual').

4.6 Where an installation has more than one owner, or the installation is comprised of more than one plant which have multiple owners, these owners will need to reach an agreement about who will be the representative owner nominated to apply and receive the NIRHI payments. Only one application will be accepted for any one eligible installation. Ofgem may request to see evidence of the agreement between multiple owners (such as a contract or signed letter of consent) as part of the accreditation process or as part of an audit.

4.7 Please note that only owners (with the exception of a representative owner or nominated individual) can receive the NIRHI. Agents or other third parties will not be allowed to receive the NIRHI on behalf of an installation's owner.

Installation capacity

⁷ Where there is more than one owner of an accredited NIRHI installation, the owner with the authority to act on behalf of all owners is referred to as the representative owner.

⁸ <http://www.legislation.gov.uk/ukpga/2011/16/introduction?view=extent>

4.8 For the purposes of the NIRHI, the installation capacity will be the total installed peak heat output capacity of the installation. For most technologies, the installation capacity should be simple to establish as it will be part of the information provided by the manufacturer. Ofgem will require details of the installation capacity as part of the accreditation process.

4.9 Where there is no standard information from the manufacturer, e.g., for bespoke equipment, as part of the accreditation process you may have to provide Ofgem with technical evidence to prove the installation capacity.

Installation capacity for CHP systems

4.10 The Regulations state that an installation's capacity is the "total installed peak heat output capacity" of that installation (except where an application for accreditation has been made on the basis of specific combustion unit(s) being eligible). For CHP systems, this relates to the total heat output of the equipment in the form of usable hot liquid or steam. Applicants will need to make a case for how the capacity has been defined, including consideration of whether heat generated is subsequently used for power generation or heating.

4.11 For example, where a biogas CHP system combusts gas in an engine to generate power, and the waste heat from this power generation is subsequently used for space or process heating (in the form of hot water or steam), the CHP system's capacity would be the rated peak heat output capacity of any heat exchangers that are used to generate the hot water or steam.

4.12 This capacity would include the capacity of a water jacket, unless it can be demonstrated satisfactorily that the heat could not be transferred from the water jacket heat exchanger to the heating system.

4.13 Please note that heat used to generate electricity is not eligible for NIRHI support, please see Chapter Five for further details.

What is an installation?

4.14 The concept of 'installation' is important in the NIRHI scheme in relation to working out which equipment must be new or for which you must not have received a grant.

4.15 An 'eligible installation' is defined in the Regulations as a plant (which includes any equipment, apparatus or appliance) which meets the eligibility criteria. The eligibility criteria include those set out in Part 2, Chapter 2 of the Regulations — which require that eligible installations must 'generate heat' using specified eligible sources of energy and technologies.

4.16 The determination of those items of plant which are integral to the generation of heat (and which will, therefore, form an eligible installation) will depend on the particular facts and circumstances of each case. However, the table below shows the position which Ofgem will usually adopt in assessing whether particular items of plant form part of an 'eligible installation' for these purposes. Our interpretation has taken into account DETI's tariff calculations that were designed to compensate for the additional cost of a renewable heat technology installation as compared to the cost of an oil installation (fossil fuel counterfactual).

Table 3: Ofgem's interpretation of 'eligible installation'

Technology Type	Examples of integral equipment usually included in definition of 'eligible installation' <i>NB: this list is non exhaustive</i>	Equipment which is usually not included in definition of 'eligible installation' <i>NB: this list is non exhaustive</i>
All heating installations (ie all technologies except biomethane)		<ul style="list-style-type: none"> <input type="checkbox"/> Heat (hot water/liquid and steam) meters <input type="checkbox"/> Heat distribution system (eg pipes delivering heat to users, heating controls, pumps, valves, radiators/heat distribution heat exchangers etc) <input type="checkbox"/> Heat storage equipment <input type="checkbox"/> Other buildings housing the plant equipment (eg boiler house) <input type="checkbox"/> Foundations
Ground Source Heat Pumps (GSHP)	<ul style="list-style-type: none"> <input type="checkbox"/> Ground or water loops <input type="checkbox"/> Heat pump unit <input type="checkbox"/> Any pumps/pumping equipment used within the ground loop or to transport water to the external heat exchanger <input type="checkbox"/> Evaporator/condenser 	
Solar thermal	<ul style="list-style-type: none"> <input type="checkbox"/> Solar collectors (evacuated tubes, flat plates) <input type="checkbox"/> Pipes and pump circulating between collector and heat exchanger 	<ul style="list-style-type: none"> <input type="checkbox"/> Associated roof fixings
Solid biomass plants (including solid biomass contained in municipal waste)	<ul style="list-style-type: none"> <input type="checkbox"/> Boiler (eg ignition equipment, heat exchanger, electrical wiring and controls, combustion chamber, grate, air control, housing/container) <input type="checkbox"/> Pipework required for the effective start up and shut down of the plant (eg back end loop/valve) <input type="checkbox"/> Fuel feed equipment (eg auger, moving floor etc) where these are likely to be integral to the operation of the plant 	<ul style="list-style-type: none"> <input type="checkbox"/> Ancillary fossil fuel equipment (eg gas start-up equipment) <input type="checkbox"/> Fuel delivery, processing (eg chipping/drying) and preparation equipment <input type="checkbox"/> Fuel store housing (eg fuel storage sheds, bunkers) <input type="checkbox"/> Flue stack***

	<input type="checkbox"/> Flue gas treatment equipment (where it is different to the equipment required for a comparable gas installation) <input type="checkbox"/> Fuel storage equipment (eg fuel hopper)**	
Biogas heat generation	<input type="checkbox"/> Boiler (eg ignition equipment, heat exchanger, electrical wiring and controls, combustion chamber, air control, housing/container) <input type="checkbox"/> Exhaust gas treatment equipment and flaring etc. <input type="checkbox"/> Biogas production plants (eg anaerobic digesters, gasifiers, pyrolysers)	<input type="checkbox"/> Feedstock treatment equipment and pre-processing equipment (eg pasteurisation equipment, materials separation equipment, silage clamps, storage buildings and slurry tanks) <input type="checkbox"/> Digestate/char treatment equipment (eg post-digestion pasteurisation equipment and materials separation equipment).
Biomethane	<input type="checkbox"/> Equipment required to convert raw biogas into biomethane suitable for injection (eg where appropriate – CO2 and oxygen removal, pressurisation equipment, propanation, odorant equipment) <input type="checkbox"/> Biogas production plant (see biogas for list)	<input type="checkbox"/> Equipment required to measure the energy content and volume of gas entering the network <input type="checkbox"/> Any flaring equipment <input type="checkbox"/> Feedstock treatment equipments and pre-processing equipment (see biogas for list)
CHP (for solid biomass, biogas and geothermal)*	<input type="checkbox"/> Equipment as specified for relevant technology above	<input type="checkbox"/> Equipment as specified for relevant technology above
Geothermal	<input type="checkbox"/> These will be determined on a case-by-case basis, based on the approach outlined above	

* CHP plants have a specific regulation in reference to what is classed as 'new' for the NIRHI. See 'New plant' section for details.

** Please note that in the case of fuel storage equipment such as hoppers for biomass boilers, Ofgem would expect at least one hopper to be new (to reflect the fact storage equipment was anticipated in the tariff) – but it is acceptable for the applicant to also have additional storage equipment in place which is not new.

*** Please note that although flue stacks would not be required to be new for NIRHI purposes, any new plant requires a health and safety assessment of the flue stack design (irrespective of the NIRHI)

NIRHI interaction with publicly funded grants and other public support

4.17 The Regulations state that:

- NIRHI support will only be available for an eligible installation if no grant from public funds or other public support has been paid or will be paid in respect of any of the costs of purchasing or installing the eligible installation, or;

- where a grant from public funds or other public support has been paid for an eligible installation that was completed and first commissioned on or after 1st September 2010 such a grant or support has been repaid to the person or authority who made it.

4.18 In practice, this means:

- Ofgem can accredit an installation only where the purpose of the grant or public support is, or will be, to meet costs other than the costs of purchasing or installing the installation; and
- an installation will not be accredited where a grant or public support (of any value) has been, or will be, paid in relation to the costs of purchasing and installing it, if it was completed and first commissioned after 1st September 2010 and that grant or public support has not been repaid in full to the person or authority who made it.

4.19 A grant from “public funds” can be a grant made by a public authority or by a person who is not a public authority but who is distributing funds on behalf of a public authority. Ofgem’s consideration of whether or not a grant has been made from “public funds” will include grants from Europe, central or devolved governments and public authorities at regional or local level.

4.20 Ofgem will take a commonsense approach to determining what constitutes a “public authority”.

4.21 Ofgem will interpret the ‘costs of purchasing and installing an eligible installation’ as including the costs of purchasing and installing any equipment, apparatus or appliance which, in accordance with the ‘What is an Installation?’ section above, it considers to form part of the eligible installation. On this basis, they do not consider that such costs would generally extend to costs incurred in purchasing and installing plant which is not needed in order to generate heat.

4.22 During the accreditation process, all prospective participants will be asked if public funds have been or will be received for an installation. If you declare that a grant has been, or will be, received (whether or not you consider the grant to be for the costs of purchasing or installing the installation) Ofgem may contact you for further information.

4.23 If you want to decline the grant offer, or pay back a grant that has already been received for the purchase or installation costs of an installation, to allow your application for the NIRHI to be considered, please contact the grant-making body or person directly. Before Ofgem can accredit your installation, you will need to provide evidence to them either that the offer has been declined or the grant has been repaid in full.

4.24 Participants have an ongoing obligation to notify Ofgem if any of the information provided in support of their application for accreditation was incorrect. This includes information relating to the receipt of public funding.

4.25 If Ofgem become aware at a later date that the information provided at accreditation in relation to grants was incorrect, they will consider taking enforcement action against the participant. Where they find that incorrect information was provided intentionally with the purpose of defrauding the scheme, they will refer the matter to the appropriate authorities. Please see Volume Two, Chapter Ten for further information on our approach to non-compliance within the scheme.

Date of completion of installation and first commissioning must be on or after 1st September 2010

4.26 Plants are only eligible for accreditation if their installation was completed and they were first commissioned on or after 1st September 2010. Please see below for the exception to this rule for CHP plants applicable in certain circumstances.

4.27 An installation will not be eligible if the installation of the plant was completed before this date, but the plant was commissioned afterwards. Ofgem will not consider applications for accreditation for installations where the installation of the plant was completed or the plant was commissioned prior to this date. They may ask for evidence of the date your plant installation was completed (eg purchase receipts) and of the commissioning date of your installation (eg a commissioning certificate). Please also note that they may ask for a photograph of your installation taken at the time it was installed for the purposes of accreditation checks and audit.

4.28 CHP installations are an exception to the requirements set out above. If a plant which was previously generating electricity only using solid biomass or biogas, was first commissioned as a CHP system on a date (the conversion date) which is on or after 1st September 2010, Ofgem will treat these installations as if they are new plants installed and first commissioned on the date of conversion (irrespective of the date on which they started generating electricity).

4.29 For avoidance of doubt, a plant commissioned before 1st September 2010 cannot be decommissioned and recommissioned after that date in order to render it eligible. This is because the regulations require that it was first commissioned after this date.

Transitional arrangements: installations commissioned between 1st September 2010 and the commencement of the scheme

4.30 Installations that were installed and first commissioned on or after 1st September 2010 but before the start date of the NIRHI are eligible for the scheme, but have to meet all the eligibility criteria for the NIRHI just as with installations commissioned after the start of the scheme. This includes the microgeneration requirements as discussed below in section 'Microgeneration Requirements (installations of 45kWth or less)' and the metering requirements which are discussed in Chapter Seven, 'Metering eligibility requirements'.

4.31 These installations will be eligible for the same 20 year period of support as for those installations commissioned after the start of the scheme, starting from the date of accreditation (which cannot be prior to the start of the scheme). For avoidance of doubt, please note that payments will not be backdated to the date of first commissioning.

New plant

4.32 Your plant must be new to be eligible for the NIRHI. Ofgem interprets this requirement as applying to all of the 'plant' which can be regarded as constituting an 'eligible installation'; that is, any equipment, apparatus or appliance which is necessary for, and integral to, the generation of heat using eligible sources of energy and technologies. For guidance on Ofgem's approach to determining the scope of plant which can be considered integral to the generation of heat, please refer to Table 3 in the 'What is an installation?' section.

4.33 Ofgem will interpret 'new' to mean plants that are new and have not been previously used. They will accept a plant as being new if it has not been previously used before being installed and first commissioned. Converted equipment will not be eligible for the NIRHI. Upon request, you should be able to provide them with delivery notes or purchase receipts as evidence that your plant is new.

Location of the plant

4.34 Accreditation is assigned to the installation at the location that is provided at application. From 18 November 2015 it is permitted for an accredited installation to be relocated provided it continues to meet the relevant eligibility requirements on the new site. See the below section for further information.

4.35 A plant can also be removed from in situ for maintenance or minor repairs, turned back on and reconnected to the heating system as long as the plant remains at the location for which it had been assigned accreditation. Removing a plant from in situ for these specified purposes will not be considered a relocation of the plant.

4.36 Should your plant require major repairs or maintenance that must be conducted at a separate location from the plant's accredited location, you must notify Ofgem before removing the plant from its accredited location.

4.37 A plant commissioned before 1st September 2010 cannot become eligible by recommissioning after that date.

Relocation of an accredited installation

4.38 From 18 November 2015, it is permitted for an accredited installation to be relocated provided it continues to meet the relevant eligibility requirements on the new site. If an accredited installation is relocated, the participant/owner must notify Ofgem within 28 days of the installation being disconnected. You will be required to submit a photograph of the closing meter reading(s) for all RHI relevant meters. Once you have relocated your installation you will need to apply for accreditation via the RHI register, and confirm in your application form that this is a relocation. We will then assess if the installation's eligibility criteria are still being met at the new location.

4.39 During this assessment we may request to see any of the information set out in Schedule One to the Regulations. The application and supporting documentation will be reviewed. Payments will resume from the date of accreditation of the installation at the new location subject to compliance with ongoing obligations, and will continue for the duration of the 20 year lifetime given when the installation was first accredited in its original location.

Eligibility for CHP plants

4.40 At the conversion date, a heat exchanger and associated equipment must have been added to an existing electricity-only plant (and used for eligible heat uses) for a CHP plant to be considered new. For more information on the CHP conversion date, see the 'Date of completion of installation and first commissioning must be on or after 1st September 2010' section above.

Installations heating one single domestic premises are ineligible

4.41 Renewable heating installations serving a single private residential premises are currently not eligible for the NIRHI. This includes single renewable heating units installed by a company, private landlord or registered social landlord, in one or more individual premises (but does not cover district heating systems where multiple dwellings are served by a central renewable heating unit).

4.42 Only installations that provide heat to non-domestic premises or multiple domestic premises are eligible for the NIRHI. Domestic premises are defined in the

Regulations as 'single, self contained premises used wholly or mainly as a private residential dwelling where the fabric of the building has not been significantly adapted for non-residential use'⁹.

4.43 For example, an eligible installation could serve:

- a single, non-domestic premises, eg a hairdresser
- multiple non-domestic premises, eg a shopping centre
- multiple non-domestic and domestic premises (mixed use), eg office space and residential flats
- multiple domestic premises, eg district heating supplying a block of flats.

4.44 In interpreting the definition of 'domestic premises' and 'single self-contained premises' we shall take into account whether those premises are treated as separate and self-contained premises for Domestic rates banding purposes. Accordingly, where a premises consists of a main property and other buildings such as outhouses, pool-houses, lean-tos etc. which are together treated as one self-contained unit in single occupation for Domestic rates, this would be likely to be treated as a 'single self-contained' premises for NIRHI purposes. Where such premises are 'used wholly or mainly as a private residential dwelling where the fabric of the building has not been significantly adapted for non-residential use', the premises will therefore be treated as 'domestic' for the NIRHI. Accordingly, where heat is generated for use solely in these premises, that heat would not be eligible for NIRHI support as it is 'for the use of one domestic premises.'

4.45 Similarly, where premises comprise a main property and adjoining property or properties (such as annexes, gatehouses, workers cottages etc.) which are themselves treated as self-contained units for Domestic Rate banding, each of these buildings will also be treated as 'single self-contained' premises for NIRHI purposes. Therefore, if each is 'used wholly or mainly as a private residential dwelling where the fabric of the building has not been significantly adapted for non-residential use', each will be treated as a separate 'domestic premises' under the NIRHI. On this basis, if each of these buildings is served by its own boiler, these boilers would not be eligible for support as each boiler would be generating heat 'solely for the use of one domestic premises.' However, if a single boiler provided heat to two or more self-contained units, this boiler would be treated as a district heating system serving multiple domestic premises and would be eligible for the NIRHI, subject to all other eligibility criteria being met.

4.46 Non-domestic premises will be business rateable, rather than being subject to Domestic Rates, although some properties, such as agricultural buildings, are exempt from paying these rates under Rates (Northern Ireland) Order 1977 Schedule 11.

⁹ Regulations, Part 2, Chapter 2, Regulation 15 (2)

4.47 In a situation of ‘a private residential dwelling where the fabric of the building’ *has* ‘been significantly adapted for non-residential use’, the Rates officer may decide that this makes all or part of the property business rateable. Therefore your premises may be viewed as non-domestic and eligible for the NIRHI.

4.48 Further guides to help you understand your domestic rate banding or business rating are available from the Land and Property Services (LPS) website

- [business rates]
- [working from home and business rates]
- [holiday lets]
- [guest houses and bed and breakfast accommodation (B&Bs)]
- [multi-occupied homes]

4.49 Enquiries on your standing in this regard should be directed to your local Domestic Rates officer, who may also be able to help you to provide evidence if required (multiple domestic rates bills or business rates bills for premises on the heating system will usually suffice), or directed to the LPS.

4.50 If you require more detail, there is further information available on the Nibusinessinfo.co.uk website

<http://www.nibusinessinfo.co.uk/bdotg/action/layer?r.l1=1073858808&site=191&topicId=1073859221&furlname=rates&furlparam=rates&ref=&domain=www.nibusinessinfo.co.uk>

Heat delivery medium

4.51 The installation must use liquid or steam as a medium to deliver heat to the eligible use. It is acceptable for the final eligible use itself to heat air (eg radiators) provided that there is a liquid or steam heat delivery system connecting the NIRHI installation and the eligible use. Direct air heating is not eligible.

Microgeneration requirements (installations of 45kWth or less)

4.52 The Regulations provide that installations of 45kWth or less from certain technologies will be required to be backed up with certification under the Microgeneration Certification Scheme (MCS)¹⁰ or an “equivalent scheme”.

4.53 Table 4 below sets out which technologies require MCS certification. Where this applies, both of the following certification requirements will need to be met:

- the plant must be certified under the MCS or an equivalent scheme, and

¹⁰ Details of which are available at www.microgenerationcertification.org.

- the plant's installer must have been certified under the MCS¹¹ or an equivalent scheme at the time of installation.

Table 4: Which technologies require MCS certification and which do not:

Technologies requiring MCS or equivalent scheme certification for installations of 45kWth or less	Technologies of 45kWth or less not requiring MCS certification
Ground Source Heat Pumps	Biogas for combustion
Water source heat pumps	Biomethane for injection into the grid
Solid biomass	Deep geothermal
Solar thermal	Solid biomass in municipal waste combustion

4.54 Equivalent schemes include Solar Keymark¹² for solar thermal installations, or any other scheme accredited under European Standard EN45011¹³ (which certifies microgeneration products and installers in accordance with consistent standards). When applying for support, applicants will be asked for details of MCS or equivalent scheme certification. If applicants intend to apply using an MCS 'equivalent' scheme, they must prove to Ofgem that both the installer and technology have been certified by a scheme which meets the definition.

4.55 The Regulations specify that MCS or equivalent certification will not be required in the following two scenarios:

- if the combined installation capacity is more than 45kWth eg where a heating system using the same source of energy and technology, eg biomass, is made up of 2 x 25kW biomass boilers, then the two boilers will not need to be MCS or equivalent certified or MCS or equivalent installed if each component plant in the system satisfies the eligibility criteria referred to in regulation 14(3) of the Regulations and neither is already an accredited NIRHI installation
- if 'additional capacity' of less than 45kWth is added¹⁴ to an existing NIRHI heating system, the additional capacity uses the same source of energy and technology and takes the total installed capacity over 45kWth, eg where a participant already has an accredited 25kWth ground source heat pump (GSHP) and applies for a second 25kWth GSHP which is connected to the same heating system, then MCS or equivalent scheme certification will not be required for the second GSHP.

Other requirements

¹¹ Ibid

¹² Please note that Solar Keymark certifies products, but not installation companies.

¹³ ISBN 0580294153. Copies can be obtained from the British Standards Institution at www.bsigroup.com

¹⁴ And first commissioned within 12 months of the first commissioning date of the original plant.

District and community heating

4.56 District heating — such as a central boiler for an apartment building, or a network of pipes delivering heat from a central installation to a number of local households or businesses — will be eligible for the NIRHI where the heat is produced by an eligible installation. District heating will be treated in the same way as any other NIRHI installation of that technology and fuel type which is generating eligible heat. There is no uplift for district heating installations. For example, a district heating system served by a 600kWth biomass boiler will be treated the same way as a 600kWth boiler heating a single building in terms of NIRHI eligibility and support levels. District heating where more than one building is being served, will be subject to the ‘complex’ metering requirements as described in Chapter Seven.

4.57 Please see the ‘Inspections and access to third party premises’ section in Chapter Two for Ofgem’s approach to instances where the eligible heat use occurs on third party premises not owned or controlled by the participant. They may also require you to provide evidence that domestic premises receiving heat from the heat distribution system are domestic and do not have ineligible uses.

Fossil fuelled and dual fuelled biomass plant

4.58 DETI policy is clear that no fossil fuel heat is to be supported, even in relation to channelling waste heat, as the role of the NIRHI is to promote progress towards targets under the EU Renewable Energy Directive. Where a fossil fuelled plant is present, it may need to be metered separately and must not contribute towards the heat generation meter readings of the NIRHI eligible plant (please see Chapter Seven for further information on meter placement). The fossil fuel derived element of any heat will not be eligible for support under the NIRHI. For example, heat generated by a solar thermal plant linked to a gas boiler would be eligible, so long as the gas boiler was metered separately and excluded from the heat for which NIRHI support was claimed. Component plants which use renewable and fossil-fuels together in a single boiler and which are not capable of separate metering are not eligible for the NIRHI.

4.59 Biomass plants must be designed and installed to use renewable fuels as their only primary fuel but have specific permitted uses for fossil fuels in the same boiler. For further details, please see the ‘Ancillary and contaminated fuels’ section in Chapter Five.

The Northern Ireland Non-Domestic RHI Scheme is currently suspended for new applications. This section provides information which is relevant for past applications. As such, some of the information may be no longer be relevant but is included here for reference purposes. Should the Scheme re-open in the future, DfE and Ofgem will revise and reissue this guidance.

Technology specific criteria



Chapter Summary

This chapter discusses the technologies and accompanying fuels eligible for the NIRHI, as well as additional eligibility criteria specific to a technology. A table of currently ineligible technologies has been included for ease of reference. Please see the following Chapter Six for further information on eligible and ineligible heat uses.

Supported technologies and fuels

5.1 To be eligible under the NIRHI, except for producers of biomethane, an installation must generate heat using one of the eligible technologies. Chapter Four discusses the general eligibility criteria of the scheme. This chapter sets out the additional eligibility criteria that are specific to a particular technology.

Solar thermal

5.2 The total installation capacity of a solar thermal installation must be lower than 200 kWth. For further information on how to determine your installation capacity, please see the 'Installation Capacity' section in Chapter Four.

5.3 Only solar thermal installations comprising liquid filled flat plate or evacuated tube solar collectors will be eligible for NIRHI support. Other types of solar thermal technologies, such as solar wall or transpired solar thermal panels, solar thermal parabolic and trough collectors are not eligible under the NIRHI.

5.4 Any solar thermal installations of 45 kWth or less must be MCS certified under the MCS or equivalent scheme. See section 'Microgeneration requirements (installations of 45kWth or less)' in Chapter Four for further information. 40

5.5 For clarity, hybrid solar photovoltaic-thermal (PVT) systems will be eligible for NIRHI support in respect of their heat output only, provided that the thermal output of the system is separately rated in kWth, there is separate thermal metering and the solar thermal aspect of the technology is either a liquid flat plate or evacuated tube type system.

Geothermal energy

5.6 Geothermal systems at all scales, including CHP systems, will be eligible for support under the NIRHI. Geothermal systems are defined as those generating heat using naturally occurring energy in the form of heat located and extracted at least 500 metres below the surface of solid earth. Installations extracting naturally-occurring energy from the ground at a depth of less than 500m will be classed as a ground source heat pump for the purposes of the NIRHI and must meet the heat pump eligibility requirements.

5.7 There is no requirement for geothermal systems to be MCS certified.

Heat pumps

General eligibility

5.8 Heat pumps of all scales that utilise heat sourced from naturally occurring solar energy stored within the ground (including ground liquid) or surface liquid are eligible for the NIRHI, providing that the heat is subsequently transferred by liquid or steam.^{15 16} We refer to such heat pumps here as 'ground source heat pumps' and 'water source heat pumps' respectively.¹⁷

5.9 Heat pumps generating heat from naturally-occurring energy located and extracted from at least 500m below the surface of solid earth are classed as geothermal installations for the purposes of the NIRHI; please see the 'Geothermal energy' section above for information pertaining to such installations.

5.10 DETI understands certain heating systems may utilise heat storage, where heat is collected and transferred to a ground based thermal store for use at a later time.

¹⁵ Regulations, Part 2, Chapter 2, Regulation 8(a)

¹⁶ This includes open loop heat pumps.

¹⁷ http://www.doeni.gov.uk/niea/grg_002_final.pdf

For example, systems may utilise inter-seasonal heat storage, where excess naturally occurring summer heat is collected and transferred to a ground based thermal store for use in winter. Ground source heat pumps then extract this heat during winter months, which may increase ground source heat pump coefficient of performance as the ground has been pre-warmed. Examples of other operating modes include diurnal or simultaneous operation, where heat is stored and extracted on a daily or synchronous basis. Where such inter-seasonal, diurnal or simultaneous operating modes apply to a heat pump, or where for any other reason some fraction of the heat provided to the heat pump does not naturally occur within the ground (including ground liquid) or surface liquid, potential applicants should consider the impacts on their eligibility for NIRHI payments, as set out in the following paragraphs.

5.11 One requirement for heat pumps, in order to be eligible for the NIRHI, is that they must extract heat that is naturally occurring within the ground (including ground liquid) or surface liquid [Reg8(a)]. Ofgem is aware that there are situations in which the source to a heat pump may also include a contribution from heat that was not naturally occurring within the ground, (including ground liquid) or surface liquid. For example, this would be the case for a heat pump system which, having injected waste heat into the ground during a cooling cycle, subsequently extracted some of this heat during a heating cycle. In such situations, any incentives under the scheme would only be payable based on that fraction of the total extracted heat that was naturally occurring within the ground, (including ground liquid) or surface liquid. For example, the heat injected during a cooling cycle would not be eligible for payment under the NIRHI, as the heat would not be naturally occurring within the ground (including ground liquid) or surface liquid. In satisfying this requirement, we would consider on its merits any case presented outlining the methodology by which the NIRHI-relevant fraction of heat could be reliably deduced, such that accurate payments could be made. Ofgem continues to welcome views on how this might be most readily achieved in practice.

5.12 Air source heat pumps, including air-to-water and air-to-air heat pumps are not currently eligible for the NIRHI, but DETI intends to introduce support for these in the second stage of phase 2. Exhaust air heat pumps are also ineligible for the NIRHI. Both ground and water source heat pumps with an installation capacity of up to and including 45kWth must be certified under the MCS or an equivalent scheme. For further information about MCS certification, see section 'Microgeneration requirements (installations of 45kWth or less)' in Chapter Four.

Heat pumps with integrated electrical immersion

5.13 Heat pumps provided as a single unit with an integrated electrical immersion heater are eligible for the NIRHI. The primary functions of the electrical immersion should be to provide top up heat as required during high demand periods or boosting hot water temperature for the thermal disinfection of legionella bacteria spores as required.

5.14 Where the heat pump installation has an integrated immersion heater, the applicant will need to declare this to Ofgem within his or her application. In these cases, where practical, the applicant will be expected to account for the electrical input to the immersion heater and deduct this. Electrical consumption of an integrated immersion could be metered separately or calculated through logging its hours of use via the heat pump control unit and multiplying by the rating of the immersion. Where this is not possible, the applicant may need to measure overall electrical input. Please contact Ofgem for further information where you have an integrated immersion heater. We will keep the approach to integrated immersion heaters under review in the light of experience during the operation of the scheme.

5.15 For larger scale, eg 20kWth capacity individual units, Ofgem do not anticipate widespread use of heat pump units with integrated immersion heaters. Where these are proposed to be used they will seek a clear explanation from the applicant why an integrated immersion is specifically required for the installation.

5.16 No heat supplied to a heating system from a non integrated electric immersion heater will receive NIRHI tariff payments. Where a non-integrated immersion heater is utilised heat meters should be located suitably to exclude any output from the immersion heater.

Coefficient of performance

5.17 In addition to the general eligibility criteria outlined above, the Regulations require both ground and water source heat pumps to have a coefficient of performance (COP) of at least 2.9.¹⁸ The coefficient of performance is defined in the Regulations as ‘the ratio of the amount of heating or cooling in kilowatts provided by a heat pump to the kilowatts of power consumed by the heat pump’.¹⁹

5.18 To ensure only heat pumps that meet the required COP are accredited to the scheme, Ofgem will ask for a statement of the heat pump’s COP and supporting evidence as part of the NIRHI accreditation process. Please see the ‘Evidence of COP required during application for NIRHI accreditation’ section below which outlines the types of supporting evidence that will be acceptable.

5.19 If you are applying for accreditation and your installation is comprised of more than one heat pump unit then please first see the ‘How to apply when you have multiple plants’ section in Chapter Two for more information on how to determine whether you should apply for accreditation for each plant separately or as a single installation. Where each heat pump unit is to be treated as a component plant making up a single installation for the purposes of the NIRHI, then the COP must be provided for each different make and model of unit comprising the installation as part of the accreditation process. As each component plant must meet the eligibility

¹⁸ Regulations, Part 2, Chapter 2, Regulation 8(c)

¹⁹ Regulations, Part 1, Regulation 2, definition of “coefficient of performance”

criteria, each unit will need to have a COP of 2.9 or above for the installation to be eligible. Where all the units comprising an installation are of the same make and model, Ofgem will only ask you to provide this information once.

Evidence of COP required during application for NIRHI accreditation

5.20 Ofgem expects participants to provide evidence that the COP has been determined in accordance with accepted industry good practice and is determined using design conditions representative of the actual installation ground loop inlet and distribution outlet temperatures for the heat pump installation i.e. its operational point.

5.21 For electrically-driven heat pumps where a natural refrigerant is not used, the EN 14511 standard sets out appropriate conditions under which the COP should be determined. The design ground loop inlet and distribution outlet temperatures should also be stated as part of your application for accreditation. The COP figure stated should be as per the rating result conducted to the closest appropriate rating temperature conditions available within table 7 of the EN 15411 standard. The most suitable location to declare this information in your application will be at the point where you will be asked to provide any further pertinent information.

5.23 For other types of heat pump where no European Standard has been issued, Ofgem would expect participants to provide details of the test conditions under which the stated COP has been determined, including reference to any industry standard or guidance which has been adhered to, and the basis on which the participant considers this approach indicative of good practice. Relevant industry standards for these purposes may include, for example, test conditions for gas-driven heat pumps as set out in the ECA Energy Technology Criteria List or as recommended by the Japanese Standards Association. Where more than one standard could be used, Ofgem would expect participants to use that which is most appropriate for the standard operating conditions of the heating system to which the installation will supply heat.

5.24 A 'performance curve' or table for COP at various rating conditions, produced under EN 15411 test conditions would be considered suitable evidence to verify the COP figure stated within the NIRHI application. This information is often included within manufacturer's technical specifications for the heat pump unit.

5.25 In addition to the specific evidence set out below, Ofgem expect participants to retain evidence relating to the heat pump's design and installation: for example, commissioning data.

(a) Suitable forms of evidence for COP for electrically driven heat pumps

5.26 Many heat pumps are sold as a packaged unit, comprising the compressor, condenser, expansion valve and evaporator. In this case, the manufacturer of the

packaged unit will be considered as the heat pump's manufacturer for NIRHI purposes.

5.27 For packaged electrically-driven heat pumps, participants will be required to state the COP of the heat pump as part of the accreditation process, and provide evidence to support this. Typically, such evidence would be one of the below:

- evidence that the appliance is listed on the MCS list or the Enhanced Capital Allowance (ECA) Energy Technology List;
- copy of manufacturer's documentation, stating the heat pump make and model and the associated
- COP, tested in accordance with EN 14511;
- copy of manufacturer's test report, stating the heat pump make and model and the associated COP, tested in accordance with EN 14511;
- copy of independent third party test report, stating the heat pump make and model and the associated COP, tested in accordance with EN 14511.

Suitable forms of evidence for gas-driven heat pumps

5.27 Gas-driven heat pumps are also eligible for the NIRHI. For such heat pumps, appropriate evidence to support the declaration of COP will encompass:

- any item listed above for electricity-driven heat pumps (replacing the requirement of testing COP in accordance with EN 14511 by the relevant test conditions including reference to any industry standard or guidance which has been adhered to), or
- design calculations by the manufacturer or installer setting out the expected heat pump performance which clearly states the heat pump COP and provides technical justification for this figure, including for the test conditions at which the COP was calculated

5.28 For some gas-driven heat pumps, manufacturers may provide documentary evidence of the primary energy ratio (PER) instead of the COP. The primary energy ratio is defined as the ratio of the energy provided to the heating system, usually as hot water, to the amount of primary energy (eg fuel) used by the heat pump. To calculate the COP in accordance with the definition in the Regulations, participants will need to convert the PER to a COP using the following formula:

Primary Energy Ratio / engine efficiency = Coefficient of performance

5.29 For example, if the heat pump engine has an efficiency of 35 per cent and a PER as declared by the manufacturer of 1.3, the equivalent COP figure would be 3.7.

5.30 For gas-driven heat pumps where the manufacturer's documentation specifies the PER only, this may be provided as evidence for the COP value declared. Ofgem may ask participants to provide evidence to support the engine efficiency figure used

in their calculation of the COP. Participants will need to enter the COP figure on the Ofgem NIRHI register as part of their application for accreditation.

Suitable forms of evidence for bespoke heat pumps

5.31 For bespoke heat pumps, ie those where the constituent components are tailored by the manufacturer or installer to meet the client's needs, there may be no standard technical documentation to evidence the installation's COP and installation capacity. For these installations participants should provide a copy of either:

- design / modelling calculations or commissioning data reflecting the actual design conditions of the installation, signed off by the manufacturer or installer setting out the expected heat pump COP and installation capacity. This should clearly state the heat pump COP and provide technical justification for this figure, including justification for the conditions at which the COP was calculated, or
- documentation from a recognised test house stating the heat pump COP at the design conditions of the installation and providing a justification for this, including a statement of the test conditions at which the COP was determined.

Reversible heat pumps

5.32 It is common, especially at the larger scale, for ground and water source heat pumps to run in reverse in the warmer months to generate cooling. Such reversible ground and water source heat pumps are eligible for the NIRHI, but only the heating generated is eligible for NIRHI support.

5.33 In accordance with the Regulations, participants must therefore ensure that their metering arrangement allows them to only measure heat generated, and where appropriate discount any cooling generated by running the heat pump in reverse.²⁰ Ofgem may ask for evidence that this is the case, either as part of the accreditation process or at any time once an installation has been accredited. Further information on meter placement for reversible heat pumps can be found in Appendix One of this volume, 'Meter placement examples.'

Determination of heat pump installation capacity

5.34 The installation capacity of a heat pump installation should be determined based on the intended design conditions (operational point). The relevant temperature conditions of the operational point should be stated in the application.

5.35 For packaged heat pump units the heating output (kW) can be evidenced through provision of a manufacturer's technical specification highlighting heating output at different operational points. The heating output for the heat pump unit, or

²⁰ Regulations, Part 4, Chapter 3, Regulation 34(3)

each individual unit where multiple plant are present, should be calculated based on the nearest operational conditions for that unit as tested by the manufacturer. A 'performance curve' or table for heating capacity at various rating conditions, produced under EN 15411 test conditions would be considered suitable evidence to verify the installation capacity figure stated within the NIRHI application. This information is often included within manufacturer's technical specifications for the heat pump unit.

5.36 Where an installation comprises multiple heat pump units and (as per Chapter Two 'How to apply when you have multiple plants') these are to be treated as component plants making up a single installation, then the overall 'installation capacity' will be the sum of the individual peak heat output of each unit.

5.37 For bespoke equipment, as part of the accreditation process you may have to provide Ofgem with technical evidence eg design data or simulation results, to verify the installation capacity stated.

Biomass

General biomass criteria

5.38 In addition to the general eligibility criteria, plants burning biomass, or biogas derived from biomass, must meet certain eligibility criteria specific to the technology type.

5.39 Biomass is defined as 'material, other than fossil fuel or peat, which is, or is derived directly or indirectly from, plant matter, animal matter, fungi or algae'²¹. Examples of fuels that often meet this definition include (but are not limited to):

- Wood logs, chips and pellets
- Straw and agricultural residues
- Food waste
- Paper/ pulp residues from the paper manufacturing process
- Biomass residues from the food processing industry
- Sewage sludge

5.40 When referring to solid biomass or biogas produced from biomass, we mean that the fuel is, or is derived from, the material in the above definition.

Solid biomass boilers

5.41 Some technologies have an upper limit on capacity to be eligible under the NIRHI, including solid biomass boilers, which are eligible at all scales up to but not including or above 1000kWth.

²¹ s.113(3)

'Solid'

5.42 Fuels need to be classed as 'solid' to be eligible for accreditation under this technology. If the fuel is gas, it would be eligible under the biogas technology category. Technologies using liquid fuel are not eligible.

5.43 'Wet' fuels such as food waste could still be considered solids (ie where solids are contained in water).

5.44 Where there is doubt about fuels which could be either solid or liquid, Ofgem will consider liquids as including the fuels listed in paragraph 2.3 of the 'Communication from the Commission on the practical implementation of the EU biofuels and bioliquids sustainability scheme and on counting rules for biofuels'.²² Liquids therefore include viscous liquids such as waste cooking oil, liquid animal fats, palm oil, crude tall oil and tall oil pitch. They will also include fuels with similar properties to these as liquids.

5.45 Ofgem will consider the state of the fuel at the heat generating plant in determining whether the fuel is a solid or a liquid. For example, if solid biomass is melted before it enters the heat generating plant (using the definition of 'eligible installation' in section 'What is an installation' in Chapter Four above), and thus enters the heat generating plant as a liquid, then Ofgem would generally consider this to be a liquid. Equally, where a fuel enters the plant in a solid state, they would generally consider this to be a solid.

Solid biomass as 'primary fuel source'

5.46 The Regulations require that to be eligible, a biomass boiler must be 'specifically designed and installed to use solid biomass as its only primary fuel source'. This means that boilers capable of operating effectively when using coal, oil, plastic waste or other fossil fuels are ineligible, as are dual-fuel or co-firing fossil fuel/biomass boilers. See the 'Requirements for plants of 45kWth and under' and 'Solid biomass plants between 45kWth' and 1 MW' sections below for information on how applicants should demonstrate this requirement.

General documents to keep

5.47 It will be a condition of accreditation that all biomass and biogas participants must keep planning permission documents, environmental applications and permits required under other legislation such as Pollution Prevention and Control Regulations (Northern Ireland) 2003). Ofgem will generally not require these at the accreditation stage, but they may ask for them as a follow-up to verify details provided about the boiler, such as the fuel(s) the boiler is designed to run on.

Heat medium

²² Available at <http://eur-lex.europa.eu/LexUriServ/LexUriServ.do?uri=OJ:C:2010:160:0008:0016:EN:PDF>

5.48 A solid biomass installation must include a boiler to be eligible for the NIRHI. The Regulations provide that the installation's heat must be transferred through liquid or steam, and this liquid or steam must be metered (see Chapter Seven for further information on this requirement). If the installation produces any direct air heating (such as from a stove), the installation may still be eligible if only the hot water component (eg from a 'back boiler') is metered. However, the installation would still need to meet the solid biomass as 'primary fuel source' outlined above.

Requirements for plants of 45kWth and under

5.49 Biomass plants of 45kWth and below must be certified under MCS or an equivalent scheme.

5.50 It is acceptable to have fossil fuel boilers connected to the same heating system (although heat generated by fossil fuel boilers is not eligible for the NIRHI and should not be included in meter readings of the NIRHI installation's output).

5.51 Plants must meet the solid biomass 'as primary fuel source' definition. MCS certify that solid biomass products are tested to meet certain standards, but the product would not automatically meet this definition merely because it has been certified by MCS.

5.52 To meet the 'as primary fuel source' definition, MCS-certified products at this scale will need to be tested to the following standards as applicable:

- Standards "BS EN 303-5:1999 Heating boilers - Part 5: Heating boilers for solid fuels, hand and automatically fired, nominal heat output of up to 300kW. Terminology, requirements, testing and marking." and "BS EN 14785:2006 - Residential space heating appliances fired by wood pellets. Requirements and test methods." – these will generally be eligible because the stoves/boilers tested to this standard and approved by MCS are generally not capable of operating on ineligible fuels²³
- Standard "BS EN 12809:2001+A1:2004 - Residential independent boilers fired by solid fuel. Nominal heat output up to 50 kW Requirements and test methods" – products produced to this standard would only meet the definition where the fuel used to test the product was a biomass fuel (as defined in the standard), rather than the fossil and peat fuels listed in the standard.
- Standard "BS EN 13240:2001+A2:2004 - Room heaters fired by solid fuel. Requirements and test methods" – these products would generally not meet the eligibility requirements, as we could not be confident that the stove (when fitted with a back-boiler) is not capable of operating primarily on ineligible fuels.

²³ Pellet stoves would also be required to operate with a back boiler, as outlined above

5.53 MCS installation companies and product manufacturers are able to provide advice on what standards each product was tested to. Most biomass products available have been tested to the BS EN 303-5:1999 standard and so meet the definition. Applicants will be asked at the accreditation stage to provide Ofgem with the name of the standard to which the product was tested (eg BS EN 303-5:1999).

Solid biomass plants between 45kWth and 1MW

5.54 Solid biomass boilers at this scale must meet the solid biomass 'as primary fuel source' definition and the applicant must demonstrate that this definition is met.

5.55 To evidence this, participants must keep documentation related to the purchase and installation of the plant that demonstrates that the boiler was 'specifically designed and installed to use solid biomass as its only primary fuel source'. Ofgem will ask for the relevant pages of these documents to verify eligibility on a sample basis.

5.56 An example of this evidence is a boiler warranty showing a fuel specification that clearly shows that the boiler is designed to use biomass as its primary fuel source, and that fossil fuel is not listed as being a fuel that can be used in the boiler. This would generally be sufficient to demonstrate that the boiler is a biomass boiler and meets the definition.

5.57 The manufacturer may also provide a reference in the warranty to detailed fuel specifications under the CEN/TS 14961:2005 or equivalent wood fuel standards, which would also generally be sufficient to demonstrate meeting this requirement.

5.58 Although Ofgem would review the requirement on a case-by-case basis, any of the following documents could be sufficient to demonstrate that this requirement is met:

- Product warranty – where it states that a solid biomass fuel should be used (eg where a warranty refers to an operating manual, and that manual states that biomass fuels are to be used)
- Planning permission/ environmental/ air quality permits from the relevant planning authority that states that solid biomass fuels should be used, where that authority has provided documentation stating that it has verified that the plant meets that permission/ permit
- Test standard – where the boiler was tested to a given standard (eg EN 303-5) and a biomass fuel was used in the test
- Construction contract or specification – where a more 'bespoke' plant has been constructed based on a building or construction specification, and the client has specified on a contract that the plant is to generate heat from biomass

5.59 Where no documents from the above list are available to the plant, an applicant could provide a combination of alternative supporting evidence to demonstrate that the requirement is met. Ofgem would need to assess this documentation on a case-by-case basis.

5.60 As a guide, some combination of the following could be used as supporting evidence to demonstrate that the requirement is met (where the documentation outlined above is not available/sufficient):

- Recommendations made in the boiler installation/ operation manual stating that solid biomass fuels should be used, and non-biomass fuels should not be.
- Technical evidence of the problems that using non-biomass fuels would cause to the operation of the plant (eg whether any tests have been carried out with non-biomass fuels, or whether non-biomass fuels have ever been used and caused problems)
- Technical evidence to demonstrate that a plant has been configured to run on biomass rather than fossil fuel (eg type of grate)
- Other evidence demonstrating that the plant was not designed and installed to use a fuel other than biomass as its primary fuel source (where the above has not been sufficient evidence)
- Insurance – where the building insurance states what kind of boiler is installed (and that this boiler operates on solid biomass)

5.61 Where the boiler has a similar configuration to fossil fuel (eg coal) boilers, Ofgem would consider this a factor against the likelihood that the boiler was designed only for biomass, and they may require stronger supporting evidence in these cases.

Ancillary and contaminated fuels

5.62 Although the NIRHI is designed to support solid biomass fuels, there are allowable uses of fossil-derived fuels to generate heat. In solid biomass plants between 45kW and 1MW, fossil fuels are permitted for 'ancillary purposes', and solid biomass fuels contaminated with fossil fuels are permitted (eg wood which has been painted, and municipal waste containing plastic). But these uses are only allowed up to certain levels. These uses, how they are measured and what evidence you need to keep on an ongoing basis, are outlined in Volume Two, Chapter Four.

Best Practice

5.63 If you would like further information on implementing a biomass project, please see the Carbon Trust's best practice guide, 'Biomass heating: a practical guide for potential users for biomass projects'²⁴. If you would like further information about the

²⁴ <http://www.carbontrust.co.uk/Publications/pages/PublicationDetail.aspx?id=CTG012>

location of suitable fuels for your biomass boiler then this is available from the biomass energy centre website²⁵. Please note that both guides are for information only and should not be construed as guaranteeing eligibility to the NIRHI.

Biomass contained in municipal waste

5.64 Installations that apply under the ‘biomass contained in municipal waste’ category can only use municipal waste as their fuel source. If the installation is to be eligible for the NIRHI on the basis that heat is being generated there from solid biomass contained in municipal waste, fuels that are not classed as municipal waste by the Regulations (eg other wastes, or solid biomass) cannot be used at the plant. The use of other fuels at the plant would mean that the solid biomass in municipal waste provisions in the scheme could not be utilised.

5.65 The Regulations specify that ‘Municipal waste’ has the same meaning as in section 21 of the Waste and Emissions Trading Act 2003 (WSET). This is:

- ‘waste from households’, and
- ‘other waste that, because of its nature or composition, is similar to waste from households.’

5.66 It is clear from this definition that where an installation uses household waste only, this waste can be viewed as ‘municipal waste’ within the meaning of the Regulations.

5.67 Where a participant wishes to use a mixture of household waste and other waste (‘mixed waste’), Ofgem will need to be satisfied that all of this mixed waste can be regarded as municipal waste. This is because installations which use biomass contained in waste other than municipal waste are not eligible for support under the NIRHI.

5.68 In assessing whether household waste or mixed waste may be treated as municipal waste under section 21 of WSET, Ofgem will refer to the List of Wastes set out in the tables at Appendix Four as this will ensure consistency with the approach taken under the GB RHI Regulations. The first table in Appendix Four shows the categories of Wastes that should be classed as municipal waste. The second shows examples of the categories from the List of Wastes that should not be classed as municipal waste.

Biogas combustion for heat

5.69 Biogas is defined as ‘gas produced by the anaerobic or thermal conversion of biomass’.²⁶ Because of this link to the term ‘biomass’ and the definition of that²⁷, this

²⁵ http://www.biomassenergycentre.org.uk/portal/page?_pageid=77,225275&_dad=portal&_schema=PORTAL

²⁶ The Energy Act 2011 113(3)

²⁷ Ibid

does not include any gas produced from fossil fuel or peat, but only from fuel 'which is, or is derived directly or indirectly from, plant matter, animal matter, fungi or algae'.²⁸ For example, this could include gas produced from food or farm waste.

5.70 The biogas installation must use one of the following conversion technologies²⁹:

- Anaerobic digestion: 'the bacterial fermentation of biomass in the absence of oxygen'
- Gasification: 'the substoichiometric oxidation or steam reformation of a substance to produce a gaseous mixture containing two or all of the following: oxides of carbon, methane and hydrogen'
- Pyrolysis: 'the thermal degradation of a substance in the absence of an oxidising agent (other than that which forms part of the substance itself) to produce char and one or both of gas and liquid'

200kWth biogas limit

5.71 Only biogas systems of under 200 kWth are eligible for NIRHI support. In other words the 'total installed peak output capacity'³⁰ of the heat generating equipment must be less than that. Please refer to the 'Installation capacity for CHP systems' section in Chapter Four for how to determine this.

Other criteria

5.72 In addition to the biogas upper limit, the Regulations state that the plant must not generate heat from solid biomass (including solid biomass contained in municipal waste).³¹ This means that where liquid or steam is heated from solid biomass, the plant would not be eligible as a biogas plant. For example log gasification boilers (and other gasifying boilers) would generally be classed as generating heat from solid biomass (as well as biogas) because significant amounts of heat from the solid biomass, in the form of hot gases generated by the biogas plant, would be transferred to the hot water. Plants such as these would instead be eligible as solid biomass plants and receive the solid biomass rather than biogas tariff.

5.73 An example of a plant which does not generate heat from solid biomass (and would therefore be classed as biogas) would be where syngas produced from a gasification process is quenched before being combusted (in an engine, turbine or boiler). Because the syngas does not contain significant amounts of heat, heat would not be passed from the solid biomass to the hot water.

5.74 Where a plant generates hot liquid/ steam from solid biomass (.e from the heat contained in the syngas before combustion is complete) through a heat exchanger,

²⁸ Ibid

²⁹ Regulations, Part 1, Regulation 2, definitions

³⁰ Please see the 'Installation Capacity' Section in Chapter Four for an explanation of this term.

³¹ Regulations, Part 2, Chapter 2, Regulation 11(c)

and another plant combusts the biogas and generates hot liquid/ steam through a further heat exchanger, this would count as two separate plants (one solid biomass and one biogas). Two applications would be made to the NIRHI, and each plant would receive the tariff applicable to that heat generation and use.

5.75 Biogas from landfill sites will not be eligible for support.

5.76 Plants configured to operate on both biogas and fossil fuel gas (eg where a single boiler is connected to both a biogas and natural gas supply), which are effectively dual-fuel biogas/ fossil fuel boilers, would not be considered to be generating heat from biogas so would not be eligible under the scheme.

5.77 Biogas can also be upgraded to make biomethane, as set out in the section on biomethane below, and/ or used directly to produce heat. Where a company produces biogas and some is combusted to provide heat, while the rest is 'upgraded' to biomethane, the plant should apply separately for accreditation of the installation generating heat from the biogas and for registration of the biomethane production.

5.78 There is no requirement for MCS certification of biogas plants.

5.79 Biogas plants will still need to comply with relevant waste and environmental permitting legislation irrespective of their participation in the NIRHI.

Combined heat and power

5.80 The heat output of CHP systems is eligible for support under the NIRHI so long as the system uses geothermal, biogas, solid biomass, or solid biomass contained in municipal waste as a source of energy.

5.81 Biomass CHP installations with a date of accreditation on or after 18 November 2015 will be eligible for one of the specific CHP tariffs. There is one tariff for new CHP installations (i.e. an installation built and commissioned as a biomass CHP installation) and one tariff for CHP installations which have converted from fossil fuel CHP. Applicants will need to provide information and evidence in the application form to demonstrate which of these tariffs are applicable. Please see the DETI website³² for the most up to date tariff table. CHP installations using municipal waste, biogas or geothermal would be eligible for the tariffs related to those respective fuel/energy sources.

5.82 Biomass CHP installations with a date of accreditation on or after 18 November do not have a limit on the permitted thermal capacity.

³² <http://www.nidirect.gov.uk/rhi>

5.83 There is an exception to the above as detailed in the Regulations³³ where a CHP plant cannot be accredited under the NIRHI, which relates to interaction with the NI Renewables Obligation³⁴ (NIRO). Details are covered in the following section.

Interaction with the Northern Ireland Renewables Obligation (NIRO)

5.84 CHP installations accredited on the NIRO prior to 1 st October 2015 and for which ROCs have been received are not eligible on the NIRHI.

5.85 Solid biomass CHP installations which first generate heat and electricity on or after 1 October 2015, may have a declaration made under Article 26(8) of the Renewables Obligation Order (Northern Ireland) 2013, that their heat is not eligible for support under any scheme other than the NIRO.

5.86 The Regulations prevent payment being made for heat generation where such a declaration has been made. However, if the technology/fuel is eligible for RHI support and consequently the declaration has not been made, then – although NIRO support will not be available for the heat generated - RHI support may be available for that heat (provided that all other requirements for entry onto the scheme are met).

5.87 CHP stations using municipal waste accredited under the NIRO and which have received ROCs are not eligible for support under the RHI irrespective of when they were installed and first commissioned.

Biomethane injection to the grid

5.89 Production of biomethane for injection into the gas grid will be eligible for the NIRHI. Please see Chapter Eight for further information.

Ineligible technologies

5.90 The earlier parts of this chapter set out the technologies which are eligible for the NIRHI. For ease of reference, Table 5 below sets out a number of technologies which are currently ineligible for the NIRHI. This is not an exhaustive list of ineligible technologies.

Table 5: Ineligible technologies

INELIGIBLE TECHNOLOGIES	
Co-firing of biomass with fossil fuel	DETI will not be supporting the co-firing of biomass with fossil fuels in single boilers under the NIRHI. Regulations place obligations on the type of boiler installed (see solid biomass eligibility section) and on the fuels used on an ongoing basis (see section on 'ongoing fuelling requirements' in Chapter 4 of Volume 2).
Exhaust air heat pumps	Exhaust air heat pumps use air extracted from inside the building, for example from kitchens or computer server

³³ Regulations, Part 2, Chapter 2, Regulation 9(2)

³⁴ Renewables (Northern Ireland) Obligation (NIRO)

	rooms, as their air source. They are particularly useful in very well insulated buildings which require mechanical ventilation. However, they are not classified as renewable under the Renewable Energy Directive as they do not rely solely on outside air and therefore will not be eligible for the NIRHI
Transpired solar thermal panels	DETI has confirmed that direct air heating and transpired solar panels will not be supported under the NIRHI as they are not counted as a renewable technology under the RED.
Fossil fuel fired CHP	The Energy Act 2011 only allows the NIRHI to support renewable energy and therefore the DETI has confirmed NIRHI will not support fossil-fired CHP.
Waste heat from fossil fuel	DETI has confirmed the exclusion of waste fossil fuel heat from the NIRHI as it is not renewable and therefore does not count towards the UK's renewable energy targets.

Heat Uses

6

This Chapter sets out

- The principles underlying DfE's policy on heat use eligible for NIRHI support
- Details of heat which will be eligible for NIRHI support
- Heat uses which will not be eligible for NIRHI support

Principles of Heat Use

6.1 The following principles underpin DfE's policy on heat uses which are eligible for NIRHI support:

- The NIRHI is designed to incentivise the displacement of fossil fuel heating by renewables, not to subsidise or reward the production of additional heat that would not otherwise have been generated
- The NIRHI is therefore intended to provide support for renewable heating where the heat generated is useable and useful and is one of the eligible purposes. Useable and useful heat means the heat load should be an existing or new requirement which would otherwise be met by an alternative heat source, not created for the predominant purpose of increasing NIRHI support payments and which is economically justifiable. Heat which is not required or usable and useful is ineligible under the scheme
- An economically justifiable heating requirement is one where the heating load and the amount of heat generated would otherwise likely have been met at market conditions by an alternative form of heating

6.2 This chapter does not apply to biomethane plants; please see chapter 8 for an explanation of the registration process for such plants.

Eligible Heat Uses

6.3 The Regulations state that the NIRHI supports heat where that heat is used in a building for ‘eligible purposes’: heating a liquid, heating water or for carrying out a process³⁵. Our interpretation of these terms is described in more detail below:

- Heating a space: the heating of rooms or other enclosed spaces within buildings, typically through the supply of hot liquid to heat emitters, such as radiators and underfloor heating
- Heating liquid: the heat of water for direct use, such as commercial and industrial hot water or for use in schools or hospitals. Heating hot water for domestic use is also permitted, provided that the eligible installation does not provide heat solely to a single domestic premise. For more information on what constitutes a single, domestic premises, see section ‘Installations heating one single domestic premises are ineligible’ in chapter 4
- Carrying out a process: the use of heat to carry out a specific process such as industrial cooking, drying (including drying of wood and other biomass fuels – however you cannot use the dried fuel to obtain further payments), pasteurisation³⁶ or chemicals manufacture. It also includes heat that is subsequently used for cooling, e.g. passing renewable heat through absorption chillers. It does not include heat that is subsequently used in the generation of electricity.
- From 18 November 2015, NIRHI also supports specific heat uses for a purpose other than in a building for drying or cleaning carried out on a commercial basis³⁷.

³⁵ The Renewable Heat Incentive Scheme Regulations (Northern Ireland) 2012, Part 1, Regulation 2 (definition of ‘eligible purpose’) and Regulation 3(2)

³⁶ For anaerobic digestion plants, the pasteurisation of feedstocks before they enter the digester, and the digestate, will be regarded as eligible processes

³⁷ The Renewable Heat Incentive Scheme Regulations (Northern Ireland) 2012 Part 1, Regulation 3(2) as amended by The Renewable Heat Incentive Schemes (Amendment) Regulations (Northern Ireland) 2015

6.4 Heat defined as an ‘ineligible purpose’ will not receive NIRHI support³⁸. Renewable heat generated to meet the heat loads described below would not be eligible for the NIRHI:

- Heating of external surfaces to prevent frost or cold temperatures³⁹
- Underground heating of open external spaces, e.g. recreational facility
- Heating of open air or partially enclosed swimming pools

6.5 The Regulations define a building as ‘any permanent or long-lasting building or structure of whatever kind and whether fixed or moveable which, except for doors and windows, is wholly enclosed on all sides with a roof or ceiling and walls’. The definition therefore has two main components: Whether the building is permanent or long-lasting, and whether it is wholly enclosed. Ofgem explain below how they will interpret these two components. Applicants must ensure that their building meets both criteria in order to receive NIRHI payments.

6.6 Ofgem will ask for information about the building(s) in which the heat is used as part of the accreditation process. A number of examples of how Ofgem will apply the definition of a building in practice is provided in the following paragraphs. The examples are not intended to be comprehensive and Ofgem will consider each application on a case-by-case basis to assess whether the definition in the Regulations is met.

6.7 In assessing whether a building or structure is ‘permanent or long-lasting’, Ofgem have regard to:

- the length of time for which it is expected that the building or structure will remain in its location
- the materials from which the building or structure (including any associated foundations) are constructed
- the degree to which the building or structure is designed to be moved and the extent of works required to effect its removal

6.8 Generally Ofgem will not consider any building or structure that has a planned time of use of two years or less to be ‘permanent or long-lasting’.

³⁸ The Renewable Heat Incentive Scheme Regulations (Northern Ireland) 2012, Part 1, Regulation 2, definition of ‘ineligible purpose’

³⁹ Trace heating of insulated pipework will in general be regarded as an eligible use. See paragraph 6.15 for further information.

In addition, Ofgem may consider a claim for capital allowances on a moveable building⁴⁰ as an indication that this building is not expected to remain in a single location on a 'permanent or long-lasting' basis.

- 6.9 As a result, Ofgem will normally consider that tents, polytunnels and similar structures erected on a temporary basis as ineligible because they do not meet the criterion of 'permanent or long-lasting building or structure'. However, moveable buildings or structures which are constructed with a view to having a long period of use such as portacabins, static caravans, greenhouses and shipping containers may be regarded as 'permanent or long-lasting' provided they are expected to remain in the same location for a sufficient period of time.
- 6.10 Structures which are erected outdoors but are themselves 'wholly enclosed on all sides with a roof or ceiling and walls' such as distillation columns and silos will be eligible. This interpretation generally extends to situations where a number of 'wholly enclosed' structures are erected outdoors on the same site.
- 6.11 For example, where a chemical or industrial processing facility comprises a series of 'wholly enclosed' structures joined by sealed pipework. This is subject to each individual structure meeting the requirement that it is 'permanent or long-lasting' and 'wholly enclosed'. It must also be shown that the eligible heat use e.g. the carrying out of a process is contained within the relevant structure(s).
- 6.12 Where heat is used for an eligible purpose within a series of 'wholly enclosed' structures which make up a chemical or industrial processing facility, each structure would normally be treated as a separate 'building' for NIRHI purposes.
- 6.13 Therefore, an installation generating heat used in a facility consisting of multiple structures will be treated as 'complex' for NIRHI metering purposes (see Chapter Seven).
- 6.14 The requirement that buildings or structures should be 'wholly enclosed on all sides' means that structures with open sides (such as barns, car ports, covered terraces etc.) and with retractable roofs are ineligible for accreditation to the NIRHI.

⁴⁰ Under Capital Allowances Act 2001, s. 23, List C, item 21.

- 6.15 Buildings or structures where one or more of its four walls contains a window or door which is significant in proportion to the area of the wall (such as retail shops with display windows, cafes with patio doors, loading bays and docks, garages etc.) are eligible for accreditation.
- 6.16 In interpreting the requirement for ‘wholly enclosed’, Ofgem will take a pragmatic approach to the existence of apertures in walls, ceilings or roofs which are not doors or windows (such as vents, flues, air intakes etc.), provided that they are small in size and number relative to the area of the wall, ceiling or roof and do not, in Ofgem’s opinion, permit the significant escape of heat.
- 6.17 As part of the accreditation process, applicants must provide information about how the heat generated by their eligible installation is used. This information will help Ofgem to verify that only heat which is eligible for the NIRHI is being supported. The information requested will include:
- The eligible purpose which is supplied with heat from the heating system of which the eligible installation forms part
 - a brief description of what the use of the heat, including whether any heat is used for ineligible purposes or exported to third parties
- 6.18 Trace heating of insulated pipework will generally be regarded as an eligible use. However, Ofgem may seek assurance, including the provision of an Independent Metering Report that the trace heated pipework is insulated appropriately and is appropriate to the system in which it is installed.
- 6.19 The Regulations permit Ofgem to request evidence that the heat for which the NIRHI is paid is being used for an eligible purpose⁴¹. Ofgem may do so as part of the accreditation process or at any time after the installation has been accredited.
- 6.20 Please see section ‘Inspections and access to third party premises’ in Chapter 2 for the approach to instances where the eligible heat use occurs on third party premises not owned or controlled by the participant.

⁴¹ The Renewable Heat Incentive Scheme Regulations(Northern Ireland) 2012, Part 4, Chapter 3, Regulation 33(o)

6.21 Participants who are unable to provide this evidence or procure the relevant rights of access from third parties may not be granted accreditation or may be subject to subsequent enforcement action as set out in Volume Two, Chapter Ten.

6.22 At accreditation stage and in subsequent annual declarations, participants must confirm that they are not generating any heat for the predominant purpose of increasing the NIRHI payments.

Ineligible Heat Uses

6.23 Some specific uses of renewable heat are excluded by the Regulations are outlined below. These examples do not constitute an exhaustive list of all ineligible purposes:

6.24 An installation may be eligible for the NIRHI if it supplies heat to one or more ineligible purposes in addition to at least one eligible purpose. However, meter readings and heat output data submitted to Ofgem for NIRHI payment purposes must not include any heat that has been used for ineligible purposes. For example, an installation pre-heating a liquid subsequently heated by a further fossil fuel plant may be eligible providing meter readings and heat output data submitted for NIRHI payment do not include heat generated by the fossil fuel plant or the heat used for ineligible purposes. Examples of pre-heating are given in metering examples five and six in Appendix One.

6.25 The following heat uses are considered ineligible:

- Cooling generated by heat pumps run in reverse (see Chapter Five)⁴²
- Renewable heat must not be used to generate electricity from the point where it is metered.⁴³ This is also the case if the heat is delivered to a third party who uses the heat to generate electricity.
- Process internal heat (sometimes referred to as ‘parasitic loads’), i.e. heat that is subsequently used in the generation of heat, is normally not eligible for NIRHI support. For example, steam used for pre-heating or de-aeration of feed water, and condensate/steam returns to an installation is not eligible

⁴² The Renewable Heat Incentive Scheme Regulations(Northern Ireland) 2012, Part 4, Chapter 3, Regulation 34

⁴³ The Renewable Heat Incentive Scheme Regulations(Northern Ireland) 2012, Part 1, Regulation 2, definition of “process”

for support⁴⁴. Process internal heat use not covered in this guidance document will be treated on a case-by-case basis. Please contact Ofgem for advice on individual cases. Chapter Seven sets out more detail of how process internal heat should be accounted for when providing meter readings and heat output data to Ofgem.

- Any heat that is lost or rejected from a system and subsequently not used for eligible purposes or which is vented directly to the atmosphere. For example heat from a heat dissipation circuit of a solar thermal system is not eligible for NIRHI support and must not be included in meter readings provided to Ofgem. Heat loss through external heat distribution pipework e.g. to transport heat between buildings, or between a standalone boiler and a building, does not serve an eligible use and as such, NIRHI payments cannot be made in respect of the heat lost.
- Heat that is wasted as a result of practices that leave it unable to serve a useful purpose is not eligible for NIRHI support. Any heat that is rendered useful or useable is generated for an ineligible purpose.

⁴⁴ The Renewable Heat Incentive Scheme Regulations(Northern Ireland) 2012, Part 2, Chapter 3, Regulation 17 & Part 5, Regulations 37 and 38

Metering Eligibility Requirements

7

This Chapter sets out:

- The types of meters that are allowed for the NIRHI, and the technical requirements they must meet
- The information relating to meters and metering arrangements which Ofgem will require during the accreditation process
- The positioning of meters relative to the installation and heat uses required to ensure that measurements are relevant and accurate and that only eligible heat is claimed
- Ongoing requirements that relate to meters in use for NIRHI purposes

Metering Eligibility Requirements

7.1 In accordance with the Regulations, participants may only claim NIRHI support on eligible heat that is delivered by any heat-conveying liquid or steam⁴⁵. Heat delivered from other sources such as direct air heating (stoves or ovens, etc.) is not eligible for NIRHI support. All eligible installations, therefore, must have one or more heat or steam meters to correctly measure the amount of renewable heat that is eligible for NIRHI support.

7.2 The requirements on metering for biomethane plants are provided in Chapter Eight.

7.3 For installations with a capacity of 45kWth and below, the MCS installation company should be able to advise participants on how to comply with the technical metering requirements set out below.

⁴⁵ The Renewable Heat Incentive Scheme Regulations(Northern Ireland) 2012, Part 2, Chapter 2, Regulation 12(1)

- 7.4 This chapter contains information which is technical in nature. Appendix One, ‘Meter Placement Examples’, provides practical examples of how the metering requirements set out in this chapter could apply in certain situations. The examples are intended to assist with understanding of how these technical requirements could apply in practice. They are illustrative examples only and are not intended to be an exhaustive list of all possible system configurations. However, Ofgem will apply the principles described in this chapter when assessing whether the metering arrangements for each heating system under application meet the NIRHI eligibility requirements.
- 7.5 Details of how to provide meter readings and heat output data to Ofgem are provided in Volume Two, Chapter Three. Ongoing obligations with respect to maintaining heat meters can be found in section ‘Maintenance of Meters’ in Volume Two, Chapter Two.
- 7.6 For the purposes of this guidance, ‘heat meters’ are meters which measure heat transferred by any liquid, typically hot water or water, and a mixture of other agents such as ethylene glycol. Steam meters are covered separately in the ‘Steam Measuring Equipment (Steam Meters) section of this chapter. Where heat and steam meters are referenced in this chapter, it is assumed they meet the requirements set out in the Regulations.

Standard of Heat Meter Permissible For NIRHI

- 7.7 Where renewable heat is delivered by a heat conveying liquid, the Regulations require that all heat meters used for NIRHI purposes must comply with the following Class 2 accuracy requirements:
- the relevant requirements set out in Annex I to the [2004 Measuring Instruments Directive \(MID\) \(2004/22/EC\)](#), and
 - the specific requirements listed in Annex MI-004 of the MID and fall within accuracy Class 2 as defined in Annex MI-004⁴⁶
- 7.8 The MID sets out the requirements for a number of measuring instruments used for trade⁴⁷. This includes meters used to measure heat by heat conveying liquids,

⁴⁶ Regulations, Part 1, Regulation 2, definition of ‘class 2 heat meter’

⁴⁷ https://ec.europa.eu/growth/single-market/goods/building-blocks/legal-metrology_en

such as hot water, in a heat exchange circuit. MID requirements in Appendix 1 include allowable errors ('accuracy classes'), durability, resistance to disturbances and inscriptions and markings that may need to be fixed to the meter. It also sets out the information which must be provided by the manufacturer for the installation, operation and maintenance of the meter. For further information about the MID, please see the [National Measurement and Regulation Office](#).

7.9 It is a condition of accreditation that the heat meters must not be tampered with in any way which would affect the meter readings of the installation.

7.10 MID provides requirements for different accuracy classes of heat meter. DfE requires a minimum of Class 2 for installations accredited under NIRHI as set out in the Regulations⁴⁸⁴⁹

7.11 To comply with the specific requirements in Annex MI-004 of the MID, all heat meters used for NIRHI purposes must comprise:

- a flow sensor (or meter) – a meter which determines the volume of fluid which has passed through a pipe within a given time period
- a matched pair of temperature sensors (such as two thermocouples) – two temperature sensors that are calibrated together as a pair to make sure the temperature difference between the input and output of the system is measured to the stated accuracy level, and
- a calculator/digital integrator – a device which uses the information provided by the flow meter and the matched pair of temperature sensors to calculate the heat energy being transferred

7.12 These components can be purchased together as an integrated meter. Alternatively, individual components or sub-components can be brought together as a heat metering system.

7.13 Where individual components are brought together as a heat metering system, the applicant must ensure that individual components are compatible. Manufacturers of a calculator/digital integrator will be able to advise on

⁴⁸ See for example, The Renewable Heat Incentive Scheme Regulations (Northern Ireland) 2012, Part 2, Chapter 3, Regulations 16 and 17.

⁴⁹ Meters that fall within accuracy class 1 as defined in Annex MI-004 of the MID and meet the other appropriate eligibility requirements are also appropriate for NIRHI purposes (as these requirements are stricter than those for Class 2).

compatibility requirements with different types of flow sensor and/or temperature sensors that meet NIRHI requirements.

7.14 A heat meter comprising individual components which all meet or exceed Class 2 requirements would be accepted as meeting the requirements of a Class 2 meter. However, if any individual component of the heat meter does not meet the Class 2 requirements, the entire heat meter will be considered to have failed to meet the requirements of a Class 2 meter.

7.15 Participants must ensure that any Class 2 heat meter used for NIRHI purposes is designed and appropriately calibrated and properly installed for the heat-conveying liquid used by the heating system.

Information to be Supplied When Applying for Accreditation

7.16 As part of the NIRHI accreditation process, Ofgem will ask for evidence which demonstrates that an integrated heat meter meets its Class 2 requirements in any or all of four ways.

7.17 The most straightforward way to demonstrate that the meter used for NIRHI purposes meets its eligibility requirements is to provide evidence that the meter complies with MID MI-004 conformity assessment procedures. Applicants may provide a digital photograph of the meter showing meter design details, its serial number and display of its 'M' and 'CE' markings and approval numbers affixed or a copy of the manufacturer's declaration of conformity.

7.18 Ofgem will also accept the following evidence of compliance with Class 2 requirements:

- A (pre-MID)⁵⁰ EEC type approval certificate showing compliance with Class 2 accuracy requirements, or a digital photograph with the meter showing the EEC approval markings and verification seals affixed to it
- A certificate from an independent test house accredited to ISO 17025 (heat meters) demonstrating compliance against the applicable European Standard (EN 1434: 2007 Parts 4 and 5) for class 2 heat meters, or

⁵⁰ MID was implemented in GB on 30 October 2006. There is a 10 year transitional period for existing (pre-MID) approvals to continue to be manufactured and placed on the market.

- An International Organisation of Legal Metrology (OIML) Class 2 Heat Meter Certificate of Conformity

7.19 Where the meter components are purchased separately, Ofgem will ask for evidence that each component meets the requirements. For example, this could include photographs of each individual component and could be supported by manufacturer's documentation or conformity assessment/testing certificates.

7.20 As part of the accreditation process Ofgem will also ask for:

- i. each heat meter's manufacturer and model, or where the components are purchased separately, the manufacturer and model of the calculator/digital integrator and flow sensor
- ii. each heat meter's serial number or, where the components of the meter are purchased separately, the serial number of the calculator/digital integrator and flow sensor component
- iii. a brief description of each meter, for example 'measures heat generated by biomass boiler' or 'measures heat being supplied to office block' to assist its identification on the system's schematic diagram (for further information about the schematic diagram, please see the section in this chapter on 'Schematic diagram')
- iv. a meter reading for each meter, and the date on which that reading was taken
- v. confirmation that all meters were installed in line with manufacturer's instructions (including any installation requirements required as part of the MID conformity assessment or other EEC, EN 1434 or OIML testing certificates as appropriate) and that the metering system is appropriate for the measurement function (e.g. the possible flow rates of the fluid being measured fall between the maximum and minimum flow rate calibration range of the flow sensor and the temperature sensors are designed to measure the possible temperature range of the liquids) and was appropriately calibrated prior to use.

7.21 Ofgem may request a copy of the MID EC-type or design examination certificate or other EEC, EN 1434 or OIML testing certificates, as appropriate, for any heat meter used for NIRHI purposes. Where the components of the heat meter are

purchased separately, the manufacturer and model of the temperature sensors and calculator/digital integrator and the serial number of the calculator/digital integrator may also be requested.

7.22 All installations that are classed as ‘complex’ for metering purposes must provide an independent report that verifies the metering arrangements in place. This will allow Ofgem to verify that all the relevant eligibility criteria have been met. Please see the ‘Independent report on metering arrangements’ section in this chapter for further details of this report and the Ofgem website for a template of the [Report](#).

7.23 In some systems, the composition of the heat conveying liquid could vary over time. This may include heating systems where the heat transfer medium comprises a mixture such as water and ethylene glycol. In these circumstances, the applicant must demonstrate that the meters installed will always meet the eligibility conditions outlined in this guidance. In reviewing such a position, Ofgem will be mindful of any procedures in place to monitor and control the concentration of the heat conveying liquid and the regime for re-calibrating the meters to compensate for changes to heat transfer liquid composition.

7.24 Applicants are not permitted to install alternative meter configurations, such as positioning the meter after the primary heat exchanger/primary heat loop, in order to remove the requirement to meter a heat conveying liquid whose composition may vary over time. A configuration of this nature could result in a meter reading contributing to misreporting of the heat generated by the installation. For example, a meter to measure heat generated by the installation that was influenced by the heat generated by another plant would not be permitted.

Standard of Steam Meter Permissible For NIRHI

7.25 Where renewable heat is delivered by steam, the Regulations set out the requirements for ‘steam measuring equipment’ (hereafter referred to as steam meters)⁵¹.

7.26 As a minimum, steam meters used for NIRHI purposes must have the following components continuously measuring the steam properties and calculating the

⁵¹ The Renewable Heat Incentive Scheme Regulations(Northern Ireland) 2012, Part 1, Regulation 2, definition of ‘steam measuring equipment’

cumulative steam energy that has passed through the measuring system shown on the system's schematic diagram:

- A flow meter – a meter which determines how much fluid (steam) has passed through a pipe over a given time period
- A pressure sensor – a device for measuring the pressure of steam flowing through the pipe
- A temperature sensor – a device for measuring the temperature of steam flowing through the pipe
- A calculator/digital integrator – a device which uses the information provided by the flow meter, temperature and pressure sensors to calculate the cumulative heat energy transferred through the pipe

7.27 These components can be purchased together as an integrated meter or purchased separately.

7.28 The Regulations also require that all steam meters are capable of displaying the measured steam pressure and temperature, the current mass flow rate and cumulative mass of steam which has passed through it since it was installed. To accommodate cases where cumulative readings may be reset during the calibration process, Ofgem will accept steam meters capable of displaying the measured steam pressure and temperature, the current mass flow rate and cumulative mass of steam which has passed through it since it was installed or calibrated.

7.29 Ofgem expects participants to install steam measuring equipment which is capable of delivering the levels of reliability and accuracy associated with accepted industry good practice. Where available, compliance with International, European or British Standards including ISO 5167 (orifice plates) is considered to be indicative of good practice, as is the use of methodologies provided in the Carbon Trust Good Practice Guide 018.

Information about Steam Meters to be Supplied when Applying for Accreditation

7.30 As part of the accreditation process Ofgem will ask for:

- each steam meter's manufacturer and model or, where the components are purchased separately, the manufacturer and model of the calculator/digital integrator and flow sensor component
- each steam meter's serial number or, where the components of the meter are purchased separately, the serial number of the calculator/digital integrator and flow sensor component
- the date of the most recent calibration of the steam meter
- a brief description of each meter which will allow it to be identified on the schematic diagram, e.g. 'measures steam generated by biomass boiler' or 'measures steam being supplied to sterilisation process' (for further information about the schematic diagram, please see the 'Schematic diagram' section below)
- a meter reading for each meter and the date on which that reading was taken
- the applicant's confirmation that all meters were installed in line with manufacturer's instructions and, where appropriate, that the metering system is appropriate for the measurement function (such as the flow rate and the calibration range of the temperature and pressure sensors), and
- The applicant's confirmation that the meters have been correctly calibrated prior to use⁵²

7.31 The most recent calibration dates and details of temperature and pressure sensors should be available on request.

7.32 Owners of installations that deliver heat by steam are required to provide an independent report that verifies the metering arrangements in place as part of the accreditation process.

7.33 This will provide further information about the steam meters and the heating system and allow Ofgem to verify that all the relevant eligibility criteria have been

⁵² The Renewable Heat Incentive Scheme Regulations(Northern Ireland) 2012, Part 2, Chapter 3, Regulation 20(2)

met. Please see section ‘Independent report on metering arrangements’ in this chapter for further details of this report.

Meter Placement: Simple and Complex Installations

7.34 This section sets out where meters need to be located in order to comply with the Regulations.

The Regulations classify installations as either ‘simple’ or ‘complex’ for NIRHI metering purposes⁵³. These classifications determine the quantities which must be measured and the location of meters⁵⁴. It also affects how payments are calculated as set out in Chapter Two, ‘Periodic support payments’, in Volume Two.

7.35 Where more than one eligible installation is connected to the same heating system (e.g. a biomass boiler and a heat pump), each eligible installation must be metered separately to ensure that its individual renewable heat contribution can be measured for NIRHI payment purposes. A separate application must be submitted for each eligible installation of a different technology.

7.36 Where an installation comprises multiple plants of the same technology (e.g. three biomass boilers installed in series), it may be possible for the plants to share a meter for NIRHI purposes, please see the ‘Shared meters’ section in this chapter for further information.

Is Your Installation ‘Simple’ or ‘Complex’ for NIRHI Metering Purposes

7.37 The Regulations require the installation to be classed as ‘complex’ for NIRHI metering purposes if any of the plants comprising an installation meet the following criteria.

- Its heat is generated by the plant delivered by steam
- The plant generates heat that is supplied to one or more ineligible purposes (see Chapter Six)

⁵³ The Renewable Heat Incentive Scheme Regulations(Northern Ireland) 2012, Part 2, Chapter 3, Regulations 16 and 17

⁵⁴ The Renewable Heat Incentive Scheme Regulations(Northern Ireland) 2012, Part 2, Chapter 3, Regulations 16 and 17

- The heat generated by the plant is used or generated within more than one building (NB, this criteria applies if heat is generated in one building and used in one or more different buildings even if the heat is transported only a short distance, and/or is transported underground)

7.38 If all plants comprising an eligible installation do not meet any of these criteria, the installation is classed as 'simple' for metering purposes and for the calculation of payments.

7.39 Where an installation is comprised of multiple plants, it is classed as 'complex' for NIRHI metering purposes where any of its component plants are classed as 'complex'.

7.40 Whether an installation is classed as 'simple' or 'complex' for NIRHI metering purposes is illustrated in Figure 4 below.

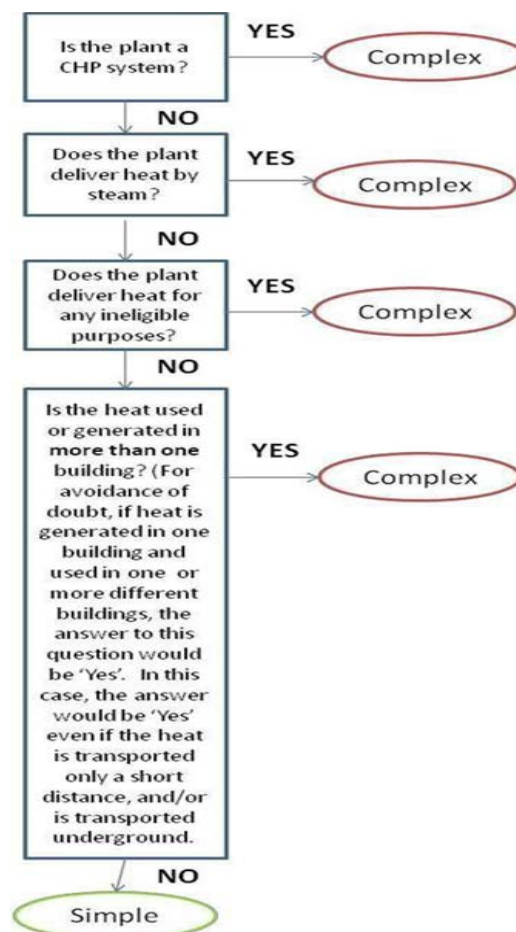

Figure 4: A flow chart illustrating whether a plant comprising all or part of an eligible installation would be classed as 'simple' or 'complex' for NIRHI metering purposes, in accordance with the Regulations. NB: Where an installation is comprised of multiple parts, it will be classed as 'complex' for NIRHI metering purposes where any of its component plants are classed as 'complex'.

7.41 In order for the metering associated with a heating plant to be ‘simple’, the plant must be located in the same building as all the uses of the heat produced. If this does not apply (for example, where the heat is transported via external heat distribution pipework for use in another building) the system is classed as ‘complex’ for metering purposes. A ‘building’ is defined by the Regulations as any permanent or long-lasting building or structure that is wholly enclosed.

Meter Placement for ‘Simple’ Installations

7.42 The Regulations allow ‘simple’ installations to meter only the renewable heat generated by the eligible installation, and to receive NIRHI support on this amount. Consequently, the heat meter must be positioned correctly to meter the heat generated by the eligible installation⁵⁵.

7.43 The temperature sensors must be installed appropriately to measure accurately:

- The temperature of the liquid returning to the installation
- The temperature of the liquid as it leaves the installation prior to entering any common pipework or vessels served by any ineligible plant such as a common header⁵⁶ or storage tank

7.44 This guidance refers to the pipe carrying the hot liquid flow leaving an installation as the ‘flow pipe’ and the pipe carrying the cool liquid flow entering an installation as the ‘return pipe’. The heat flow meter must be located on either:

- the return pipe directly entering the eligible installation
- the flow pipe directly leaving the eligible installation

7.45 The heat meter calculator/digital integrator must be correctly configured for the installed location of the flow meter and temperature sensors as well as the properties of the heat conveying fluid.

⁵⁵ As shown in Figure 4, an installation that is classed as ‘simple’ for NIRHI metering purposes cannot deliver heat by steam, and therefore steam meters would never be required.

⁵⁶ A ‘common header’ is the main pipe to which plants supply heat, and from which heat uses are supplied. A heating system may have multiple common headers.

7.46 Figure 1.1 in Appendix One provides an example of these principles apply in practice.

7.47 Where an eligible installation is classed as simple for NIRHI metering purposes, the participant will receive NIRHI payment on the kWth it generates as measured by its Class 2 heat meter(s). For further information about how NIRHI payments are calculated, see Chapter 5 in Volume Two.

Meter Placement for ‘Complex’ Installations where the Heat Transfer Medium is a Liquid

7.48 Any installation where heat is delivered by a liquid which does not meet the ‘simple’ criteria will be classed as ‘complex’ for NIRHI metering purposes. This section describes the meter placement requirements for heating systems where the heat transfer medium is a liquid. Heat transfer by steam is covered separately in the ‘Meter Placement for ‘Complex’ Installations where the Heat Transfer Medium Is Steam’ section of this chapter.

7.49 For complex installations where the heat transfer medium is a liquid, the heat meters must directly measure three quantities for any heating system of which the installation forms part (hereafter referred to as ‘the heating system’):

- the heat generated by the eligible installation prior to any common pipework or vessels served by any ineligible heat generating plant
- the total heat generated by all plants supplying hot liquid to the heating system (this applies to all plants, whether they are eligible for the NIRHI or not), and
- the heat used for eligible purposes by the heating system⁵⁷

7.50 Meters used to measure these quantities must be Class 2 heat meters or better.

7.51 For all three quantities, the flow meter component of the heat meter should be located on either:

- the return pipe directly entering the installation/heat generating plant(s)/eligible purpose, or

⁵⁷ The Renewable Heat Incentive Scheme Regulations(Northern Ireland) 2012, Part 2, Chapter 3, Regulation 17(2)

- the flow pipe ⁵⁸ directly leaving the installation/heat generating plant(s)/eligible purpose

7.52 The temperature sensors must be placed so that they measure:

- the temperature of the liquid returning to the installation/heat generating plant(s)/eligible purpose, and
- the temperature of the liquid as it leaves the installation/heat generating plant(s)/eligible purpose

7.53 Figure 1.2 in Appendix One is an example of a complex installation which uses a liquid as its heat transfer medium.

Metering Heat Where There are Multiple Buildings

7.54 Ofgem is required by the Regulations to make payment only on heat used for eligible purposes. Since heat lost in distribution between buildings is not an eligible purpose, it will not be included in any payment. Participants are therefore generally expected to meter individual buildings.

7.55 However, in exceptional circumstances where it would be unduly burdensome to do so, Ofgem may consider the use of a heat loss calculation to calculate heat lost in distribution between buildings. Applicants wishing provide a heat loss calculation must provide Ofgem with evidence that the installation of additional meters would be unduly burdensome for one of the following reasons:

- physical constraints, reasons of safety or environmental conditions
- a class 2 heat meter or steam measuring equipment would provide less accurate results than a heat loss calculation
- the cost of installing additional meters would be disproportionate in relation to the total cost of the installation, or
- the administrative cost to Ofgem to process information from a class 2 heat meter would be disproportionate in relation to the amount of heat that may be measured

⁵⁸ The pipe carrying the hot water flow leaving an installation or heat use is commonly referred to as the flow pipe.

7.56 Ofgem will consider heat loss calculations and proposals for alternatives to metering individual buildings on a case-by-case basis. Applicants may be asked to provide verification of these calculations by an independent professionally qualified person.

Alternative Approach Where Separate Heating Circuits Are Fed By a Common Distribution System

7.57 In general, plant supplying heat to the complex heating system must be metered for heat output. However, Ofgem is mindful that, in some circumstances, this requirement may be overly burdensome. For example, a building which is supplied from a district heating system via a heat exchanger may contain a back-up or supplementary boiler, the output of which is completely isolated from the main district heating circuit. An example of such a system is provided in Appendix One, Figure 1.8. To accommodate this type of situation, Ofgem may consider proposals to measure the eligible heat delivered to this building using a single meter, where:

- heat is supplied to a building via a heat exchanger such that the building has a heat distribution system separate to the main distribution loop served by an installation
- there are no ineligible uses within the building, and
- The meter is capable of capturing only heat used for eligible purposes and does not include any heat used for ineligible purposes; and
- It can be demonstrated that any heating plant within the building makes no contribution to providing heat for any use outside of the building which it serves.

7.58 In these circumstances, the tariff calculation formula for heat generated by plants supplying heat to the heating system, of which the installation is part, would not include heat generated by plants within this building. For more details on how payments are calculated, see Chapter Five 5 of Volume Two.

Meter Placement for ‘Complex’ Installations Where the Heat Transfer Medium Is Steam

7.59 All installations where steam is the heat transfer medium are classed as 'complex' for NIRHI metering purposes⁵⁹. All steam meters used for NIRHI purposes must meet the technical requirements set out in the 'Steam Measuring Equipment (Steam Meters)' section of this chapter. Where heat is used for eligible purposes in more than one building, the section on 'Metering heat where there are multiple buildings' applies.

7.60 The Regulations require steam meters to be positioned to measure:

- the heat generated in the form of steam by the eligible installation
- the total heat generated in the form of steam by all plants supplying heat to the heating system
- the heat in the form of steam used for eligible purposes by the heating system - this will require:-
 - a steam meter to measure the energy in the form of steam that is delivered to the eligible purpose
 - heat meters or steam meters positioned to measure heat which is returned to the installation from the eligible installation in the form of condensate, low pressure steam, or a two phase flow⁶⁰ of condensate and steam⁶¹; and
 - heat meters and/or suitable calculations to establish any heat that is 'sent to drain' and not returned to the eligible installation

7.61 The energy in the hot water delivered to the eligible installation and any ineligible plant(s) does not need to be metered as the feed water temperature for all plants will be the same⁶².

7.62 Where any combination of condensate, non-condensable gases and steam are discharged, the steam meter(s) measuring steam delivered to an eligible purpose must be positioned where they will not include heat lost through discharge.

⁵⁹ The Renewable Heat Incentive Scheme Regulations(Northern Ireland) 2012, Part 2, Chapter 3, Regulation 17(1)

⁶⁰ two-phase flow is one in which two phases flow simultaneously – in this case, the two phases are gas (steam) and liquid (water)

⁶¹ The Renewable Heat Incentive Scheme Regulations(Northern Ireland) 2012, Part 2, Chapter 3, Regulation 17(2)

⁶² As the heat generated by the eligible installation and the total heat generated by all plants that deliver heat to the heating system only appear in the tariff calculation formula as a ratio, the enthalpy difference between the steam and the feedwater cancels out in the tariff calculation formula. For further details of this formula, please see Chapter 5 of Volume 2.

- 7.63 Generally, this requirement applies to devices including steam traps and blowdown valves. However, Ofgem is aware that well maintained steam traps and related devices may be an integral part of best practice system design. Steam traps and related devices which are well maintained and are appropriate to the system are not considered to be an ineligible use of metering purposes. However, Ofgem may seek assurance, including through the Independent Metering Report that such devices are not inappropriate to the system and are not poorly maintained.
- 7.64 Where steam is used for internal processes, such as feed water pre-heating, de-aeration or any other similar returns to the installation, the steam meter(s) measuring steam delivered to the eligible installation must be positioned to exclude steam used for internal purposes. Where this is not possible it is permissible to calculate the amount of steam used for internal purposes using metering by difference (see the 'Metering by difference' section in this chapter for further details). For further information about process internal heat, see Chapter 6.
- 7.65 Often the fluid that returns from the eligible installation will be a two-phase mixture of hot water and steam. Ofgem expects applicants to know the conditions of this returned fluid in order to determine whether a steam meter or heat meter is most appropriate for measuring its energy content. Ofgem may ask for evidence showing that the choice of meter is appropriate for the typical conditions of the returned fluid.
- 7.66 Where the returned fluid is wholly or primarily hot water, the heat meter should have one temperature sensor in the return pipe from the eligible installation and use the datum used by the steam meters in place of the second temperature sensor. Typically this datum will be 0°C⁶³.
- 7.67 Where the fluid returned from the eligible use is wholly or primarily steam, additional temperature and pressure sensors must be located in the return pipe leaving the eligible installation (in addition to a flow meter).

⁶³ See for example, https://www.chpqa.com/guidance_notes/GUIDANCE_NOTE_23.pdf

- 7.68 In line with industry good practice, Ofgem expects participants to return as much fluid from the eligible installation as practically possible and may ask for information or evidence to confirm this is the case.
- 7.69 Flow meters, pressure sensors, temperature sensors and calculators/digital integrators must be clearly marked on the schematic diagram. The schematic diagram must also show which meter components are used to derive the energy measured by particular steam meters, as shown in Figure 1.3 in Appendix One, 'Meter Placement Examples'.

Location of Meters on Boilers with Heat Recirculation

- 7.70 Ofgem is aware that it is common for certain boiler types to be incorporated into heating systems in conjunction with a 'back end loop' which recirculates heat directly to the boiler while bypassing the main heating circuit or any further heating loads. Ofgem considers that it is best practice to place meters after the back end loop in order to protect against recirculated heat being measured for the purposes of NIRHI payment calculations.
- 7.71 An example of this type of meter placement is given as Example 2 in Appendix One. Ofgem will examine evidence that emerges through the administration of the scheme, and may at a later date require meters to be placed after the back end loop in all cases.

Biogas-Specific Metering Requirements⁶⁴

- 7.72 Any heat generated by the plant after it has passed the meter used to calculate the NIRHI payment must be measured and deducted from the final NIRHI payment calculations. An example of heat generated in this way could be waste heat generated from the combustion of biogas which is subsequently returned to the process of producing the biogas at the plant (for example, where hot water heats the digester).
- 7.73 At accreditation stage, Ofgem will ask how this fits in to the overall heat metering process at the plant. Due to the metering requirements, the heat will have to be transferred in the form of liquid or steam.

⁶⁴ The Renewable Heat Incentive Scheme Regulations(Northern Ireland) 2012, Part 2, Chapter 3, Regulation 21

Biogas plants are specifically excluded from delivering hot air from the heat generating plant to the biogas production plant⁶⁵.

- 7.74 Any other heat involved in the production of the biogas at the biogas production plant must also be measured and deducted from the overall NIRHI payment calculation. For example, where water is heated by a fossil fuel or renewable boiler is used to raise the temperature of an anaerobic digester, the heat generated must be measured and deducted.
- 7.75 At the accreditation stage, Ofgem will ask applicants to provide details of other heat uses involved in biogas production and how these uses will be measured in compliance with the standard class 2 heat meter requirements. When beneficiaries provide quarterly periodic information, other heat uses must be entered on to the system and deducted from the overall payment.
- 7.76 The exception to this requirement is when heat is contained in feedstock used at an anaerobic digestion plant (e.g. following pasteurisation of the feedstock). The heat in this feedstock does not need to be measured or deducted.

Shared Meters

- 7.77 An eligible installation comprised of multiple component plants that use the same source of energy and technology may use a single heat or steam meter to measure the heat generated by some or all the component plants. This is providing that those plants are eligible to receive the same tariff, share the same tariff start date and tariff end date and, in Ofgem's opinion, a single meter is capable of measuring the required quantity⁶⁶.
- 7.78 This concession does not apply where additional NIRHI capacity is added after the original installation has been accredited. For further details on additional capacity, please see Volume 2, Chapter 7.
- 7.79 Ofgem will generally permit a shared meter where the heat generated by one or more of the plants comprising the eligible installation can be directly metered by a single heat or steam meter.

⁶⁵ The Renewable Heat Incentive Scheme Regulations(Northern Ireland) 2012, Part 4, Chapter 3, Regulation 33(h)

⁶⁶ The Renewable Heat Incentive Scheme Regulations(Northern Ireland) 2012, Part 2, Chapter 3, Regulation 18

- 7.80 For example, the return temperature sensor must be placed prior to any heat generated from other sources entering the heating system and the flow temperature sensor after any pre-heating. Where such direct measurement is not possible, each plant will need to be metered individually.
- 7.81 Figure 1.4 in Appendix One, 'Meter Placement Examples', gives an example of how this might work in practice.
- 7.82 A shared meter must be clearly highlighted on the schematic diagram and in the application for accreditation where an eligible installation is comprised of multiple component plants.

Installation in Series

- 7.83 Where one eligible installation is used in series with another eligible installation of a different technology type (for example a solar thermal installation preheats feed water to a biomass boiler) heat meters, or steam meters as appropriate, must be positioned to directly measure the heat generated by each installation and to allow measurement of the contribution made by each eligible installation to the total heat generated. An example is provided in Appendix One.

Metering By Difference

- 7.84 In general, Ofgem requires direct measurements⁶⁷ as combining meter readings to obtain a quantity required for the NIRHI tariff calculation may affect the accuracy with which that quantity has been measured.
- 7.85 However, Ofgem recognises that, in some circumstances, direct measurement may not be possible and will give consideration to measuring by difference on a case-by-case basis. For example, if a Class 2 heat meter measures quantity A and another Class 2 heat meter measures quantity B, Ofgem may permit these measurements to be used to calculate the NIRHI-required quantity C, where "C = A – B".
- 7.86 Where Ofgem grants permission for measuring by difference all relevant metering equipment must be calibrated at the same time by the same person to reduce any calibration errors.

⁶⁷ The exception to this is the measurement of heat used in systems where heat is delivered by steam.

7.87 Any agreement Ofgem makes to measuring by difference will be in writing, together with agreement on the means of calculation.

Installation of Meters

7.88 As part of their application for NIRHI accreditation, applicants must declare that, to the best of their knowledge, all heat or steam meters (and meter components where these were purchased separately) conform to the manufacturer's specifications (e.g. they have not been modified in any material way or, if repaired or refurbished, replacement parts were sourced from the original manufacturer) and maintain relevant accuracy within the class 2 or higher eligibility requirements.

7.89 Applicants must also ensure that all meters and their associated components are installed in accordance with the manufacturer's specifications (including any installation requirements under the MID EC-type or design examination certificate or other EEC, EN 1434 or OIML testing certificates as appropriate). For example, manufacturers of flow meters often stipulate that the meter must:

- have a flow conditioner or be placed a defined number of upstream and downstream straight pipe diameters from any obstruction or plant to ensure that the meter is not affected by flow disturbances or perturbations
- Have the temperature and, where appropriate, pressure sensors placed to ensure that the temperature or pressure measurement is that of the heat-conveying liquid or steam and is not affected by other factors such as other heat sources or the pipework configurations.

7.90 Applicants must ensure that the meters installed are appropriate for the operating conditions of the heating system.

7.91 Participants should keep records of the relevant manufacturer's instructions and relevant installer's receipts/documentation as Ofgem expect them to be available upon request.

Schematic Diagram

- 7.92 Applicants must provide a schematic diagram of the installation and the heating system of which it forms part. This diagram is a key part of the application for accreditation.
- 7.93 As appropriate to the heating system of which the installation forms part, the diagram must clearly show:
- the relative positions of the eligible installation(s) including any component plants and any ineligible plant(s), eligible heat use(s), any ineligible heat use(s) and heat rejection facility/facilities
 - the relevant pipework connections between all plants within the eligible installation(s)
 - the relevant pipework connections between all eligible installations, all ineligible plants and eligible or ineligible uses of heat, and
 - the relative positions of the relevant heat and steam meters and their associated components as listed under the sections in this chapter on ‘Heat Meters’ and ‘Steam Measuring Equipment (Steam Meters)’
- 7.94 With regard to each meter used for NIRHI purposes, the schematic diagram should include a key and must clearly show:
- the meter sub components’ positions, e.g. the positions of temperature sensors, pressure sensors, flow meters and any flow conditioners/straighteners
 - the measurements which will be combined by the calculator/digital integrator to generate the meter reading
 - the meter serial number as listed in the applicant’s application for accreditation

Independent Report on Metering Arrangements

- 7.95 In accordance with Schedule 1 of the Regulations, where an installation has a capacity of 1MWth or above or is classed as complex for NIRHI metering purposes, Ofgem require an independent report (the ‘Report’) by a competent

person demonstrating that the metering and measuring requirements imposed by Chapter 3 of Part 2 of the Regulations have been met⁶⁸.

7.96 Ofgem generally will not require installations that have an installation capacity of 45kWth or below to submit the Report. However, Ofgem may ask for a Report if the other evidence provided at accreditation does not prove that the metering arrangements for the system meet the scheme requirements. Applicants applying for accreditation of plant with an installation capacity of 45kWth or below should be prepared to provide a Report if requested to do so but may choose not to obtain the Report in advance of their accreditation application.

7.97 A Report will also be required in the following circumstances:

- where additional NIRHI capacity⁶⁹ takes an accredited installation's capacity over 1MWth
- where additional NIRHI capacity takes an accredited installation's capacity over 45kWth and the installation is considered complex for NIRHI metering purposes,
- where a change is made to the installation/heating system that results in an NIRHI accredited installation moving from a simple to complex classification for NIRHI metering purposes⁷⁰ - it is a condition of accreditation that should this situation arise, participants must provide an independent metering report for their accredited installation

7.98 Further information on additional NIRHI capacity and on simple and complex classifications can be found in Chapter 7 in Volume 2 and Chapter 7 on the Volume of the Guidance.

Who Can Write The Report?

7.99 In order to ensure the Report is written to an appropriate standard, the Regulations require the Report to be completed by a 'competent person'.

⁶⁸ Regulations, Schedule 1, paragraph 1 (2)(v)(v)

⁶⁹ Additional NIRHI capacity' is defined in the Regulations (Part 6, Regulation 42(2)) as a plant which is—

(a) first commissioned after the date on which an accredited NIRHI installation ('the original installation') was first commissioned;

(b) uses the same source of energy and technology as the original installation; and

(c) supplies heat to the same heating system as that of which the original installation forms part

7.100 Mindful of the emerging nature of heat metering, Ofgem currently interprets 'competent person' to mean a person that meets all of the following criteria:

- i. an experienced and suitably qualified engineer (at least HND or equivalent in an engineering discipline from a recognised academic institution)
- ii. has demonstrable experience and expertise in flow measurement and heat/steam measurement systems demonstrated by training and development records
- iii. has a relevant background (involved in energy, utilities, building services, heating system design, heating system operation & maintenance)
- iv. covered by Professional Indemnity Insurance of at least £1m (through employer or directly)
- v. is unbiased and impartial

7.101 Ofgem will keep these criteria under review and, in future, may ask for further competence criteria to be met as the number and levels of qualification of people in the marketplace increases.

7.102 Applicants may be required to demonstrate to Ofgem's satisfaction that the competent person is unbiased and impartial. Ofgem will consider each case on its facts but considers that a competent person is unlikely to be regarded as unbiased and impartial where, for example:

- they are, or are an employer of, the owner or heat user
- they are related to the owner or heat user;
- they are contractually obliged to author Reports exclusively for a given owner
- the submission of the Report could have a material impact on a significant portion of their income

7.103 Generally, the designer or meter installer may complete the Report providing they are in a normal arms-length commercial relationship with the applicant and that none of the criteria listed in the previous paragraph apply.

- 7.104 Ofgem will keep under review the definition of persons they would consider likely to be regarded as unbiased and impartial.
- 7.105 Ofgem recognises that some large organisations intending to apply for NIRHI accreditation may wish to use in-house expertise to complete the Report. Ofgem anticipates that industry-led schemes may emerge that will certify that a person is appropriately qualified and that they are carrying out their work in a professional and independent manner. A scheme of this nature would be expected to undertake regular audits of members' activities. Where such schemes emerge and Ofgem is satisfied that the certification requirements meet its needs, certification under these schemes may be accepted as evidence of both competence and independence even if the person completing the Report is an employee of the NIRHI applicant.
- 7.106 The competent person producing the Report must visit the installation prior to completing the Report. Where a Report is required, applicants must ensure it is carried out by a competent person who meets all the necessary criteria. Trade bodies should be able to provide further advice on professional competence.

What Should the Report Cover?

- 7.107 Ofgem has developed a Report template to ensure that all Reports are consistent and provide all the information necessary to confirm metering arrangements are appropriate for the NIRHI.
- 7.108 This template is available on the [Non-Domestic Renewable Heat Incentive \(RHI\) Ofgem](#) website. The competent person must follow this template as closely as possible.
- 7.109 The Report will cover the installation's metering arrangements for NIRHI purposes, including:
- whether meters and sensors are correctly positioned
 - confirming that where any steam traps or related devices regarded as eligible for metering purposes are observed, there is no evidence that these are inappropriate to the system, inadequately maintained or inappropriately vented

- whether meters and sensors are installed in accordance with the manufacturer's instructions and, where relevant, any installation requirements required as part of the MID EC-type or design examination certificate or other EEC, EN 1434 or OIML testing certificates where appropriate
- whether meters and sensors meet the technical requirements set out elsewhere in this chapter
- whether the system is configured so that any significant heat losses are accounted for by the meter and sensor positioning
- whether the schematic diagram is an accurate representation of the installation and the heating system of which it forms part

7.110 The competent person must sign a declaration confirming that they meet the competency criteria and that the information provided in the Report is accurate to the best of his or her knowledge.

What Happens If Ofgem Is Not Satisfied With The Report?

7.111 If Ofgem is not satisfied with all or any portion of a Report (for example, if the Report is not completed on the template provided), Ofgem will notify the applicant that the Report will not be reviewed until it is provided on the template. It is the applicant's responsibility to resolve any problems with the Report and resubmit a new or amended Report as appropriate. This may require the applicant to obtain further verification and sign off from the competent person who completed the Initial Report.

The Northern Ireland Non-Domestic RHI Scheme is currently suspended for new applications. This section provides information which would have been relevant for past applications. As such, some of the information may be no longer be relevant but is included here for reference purposes. Should the Scheme re-open in the future, DfE and Ofgem will revise and reissue this guidance.

Registration for biomethane producers



Chapter Summary

This chapter sets out the registration requirements for producers of biomethane.

Biomethane as a developing technology

8.1 In this chapter Ofgem outline how biomethane producers could demonstrate that they meet the requirements in the Regulations. All applications will be reviewed against the legislative requirements.

8.2 Due to the developing nature of this technology, Ofgem advise developers to contact them early in the process for informal guidance on how legislative requirements can be met.

Existing regulatory framework

8.3 There is an existing regulatory framework relating to the injection of gas onto the gas network, for example the Health and Safety Executive Northern Ireland (HSENI) regulate the health and safety aspects of the entry of gas on to the network.⁷¹ These existing regulatory requirements should be adhered to irrespective of any application for registration under the NIRHI, and furthermore registration under the NIRHI should not be regarded as verifying compliance with any other piece of legislation.

⁷¹ (http://www.hseni.gov.uk/guidance/guidance/topics/gas_3_coloumn.htm)

8.4 If a potential participant has questions concerning producing biomethane for entry onto the network, please contact Ofgem directly.

Biomethane registration

8.5 Biomethane producers are treated differently to other participants in the NIRHI because the NI Assembly has decided that the regulations and standards currently in place for biomethane injection are sufficient to ensure that the NIRHI requirements are met, so no further NIRHI-specific accreditation standards are necessary. As a result, the Regulations describe the process for biomethane producers as 'registration' rather than accreditation.

8.6 Biomethane is defined in section 113 of the Energy Act 2011 as 'biogas which is suitable for conveyance through pipes to premises in accordance with a licence under Article 8 (1) (a) of the Gas (Northern Ireland) Order 1996 (S.I. 1996/275(N.I. 2.))

8.7 As biogas is derived from biomass, Ofgem therefore need assurance at the registration stage that the biogas is indeed from biomass and not some other source. This may include, for example, a description of where the feedstocks came from and what processes the feedstocks have gone through.

8.8 For the gas to be considered 'suitable for conveyance' (or transported in accordance with a gas transporter's licence), it will have to meet any health and safety criteria laid down by the HSENI and any consumer protection measures that are in place within the industry.

8.9 Ofgem will therefore require documentation from the participant to demonstrate that the biomethane produced meets, or is expected to meet, all of the HSENI requirements on gas safety. They will also require, where appropriate, evidence that any consumer protection conditions (eg relating to the gross calorific value (GCV) of the gas) have been met, in order for us to verify that the biomethane produced may be considered 'suitable for conveyance'.

8.10 There is a point at which biogas (which itself is the gas formed by the conversion of biomass) becomes biomethane under the Regulations. This point is when the biogas has met all of the conditions required to be 'suitable for conveyance'. For example, biomethane production may involve adding propane to the biogas in order to alter its GCV or odourising or pressurising the biogas before it is suitable for conveyance. Ofgem therefore consider that, where more than one entity is involved in producing the biomethane from biogas (or, ultimately, from biomass), the entity which bears the cost of carrying out the final production process(es) necessary to bring the biogas within the definition of biomethane under the Regulations is to be regarded as the 'producer' of that biomethane for NIRHI purposes. For example, where a biogas producer contracts with third parties to

‘upgrade’ the gas to a form suitable for conveyance, it would be the biogas producer that was the biomethane producer for the purposes of the NIRHI.

8.11 The Regulations⁷² state that biomethane producers will need to provide ‘details of the process by which the applicant proposes to produce biomethane and arrange for its injection’. This is to determine that the party is the producer of the biomethane, and has arranged access for its conveyance through pipes.

8.12 Further documentation Ofgem will therefore ask for at the registration stage to accompany the application for registration is:

- a schematic diagram showing the process of biomethane production from the biogas plant(s), and the point of entry on to the network, and
- extracts of contracts and the Network Entry Agreement with relevant third parties relating to the agreement to convey the gas on to the pipeline network.

Assurance

8.13 In order to help ensure compliance with the scheme, Ofgem may periodically require participants to provide an independent, third party verification of their biomethane production, to confirm that the information provided to Ofgem is correct and that the biomethane has come from renewable sources.

How to register

8.14 As for all other prospective NIRHI participants, biomethane producers should apply to register as a participant under the NIRHI either through the Ofgem NIRHI website or via a paper application for registration. Please note that applying via a paper application may take considerably longer to process.

8.15 Ofgem cannot register an applicant if a grant from public funds or other public support has been paid or will be paid in respect of any of the equipment used to produce the biomethane for which they wish to receive payments.

8.16 A grant from ‘public funds’ can be a grant made by a public authority or by a person who is not a public authority but who is distributing funds on behalf of a public authority. Ofgem’s consideration of whether or not a grant has been made from ‘public funds’ will include grants from Europe, central or devolved governments and public authorities at regional or local level.

8.17 Ofgem will take a common sense approach to determining what constitutes a ‘public authority’.

8.18 Ofgem will interpret the ‘equipment used to produce the biomethane’ in accordance with Table 3 in the ‘What is an Installation?’ section above.

⁷² Regulations, Part 3, Regulation 25(2)(c)

8.19 During the registration process, prospective participants will be asked if public funds have been or will be received in respect of any of the equipment used to produce biomethane. If you declare that a grant has been, or will be, received (whether or not you consider the grant to be for any equipment used to produce biomethane) Ofgem may contact you for further information.

8.20 Participants have an ongoing obligation to notify Ofgem if any of the information provided in support of their application for registration was incorrect. This includes information relating to the receipt of public funding.

8.21 If Ofgem become aware at a later date that the information provided at registration in relation to grants was incorrect, they will consider taking enforcement action against the participant. Where they find that incorrect information was provided intentionally with the purpose of defrauding the scheme, they will refer the matter to the appropriate authorities. Please see Volume Two, Chapter Ten for further information on the approach to non-compliance within the scheme.

8.22 Ofgem also cannot register an applicant if it would mean NIRHI support being paid to more than one participant for the same biomethane.

8.23 It will be a condition of registration that you must tell Ofgem within 28 days of any change to your circumstances which may affect your eligibility. You may contact them with this information, or, depending on the information that has changed, amend your details in your online account. If the new information you supply affects your eligibility to receive NIRHI payments shall notify you and advise you as to what they intend to do in the circumstances.

8.24 The date of registration for a producer of biomethane means the first day falling on or after the date of receipt by Ofgem of the application which Ofgem is satisfied is complete with all required information included. Assuming that you meet the requirements of the NIRHI for biomethane producers, then the registration date for a postal application would be the date that Ofgem received your completed, signed application.

8.25 Once you are a participant in the scheme, you are able to receive support. Ofgem will send you a statement of eligibility which will include the following:

- the date of registration
- the applicable tariff rate for the biomethane injected
- the process and timing for providing energy measurement data
- details of the frequency and timetable for payments
- the tariff lifetime and the tariff end date for the tariff payments
- the terms and conditions for your ongoing participation in the scheme.

Fuel measurement and sampling questionnaire

8.26 Participants will be asked to complete a fuel measurement and sampling (FMS) questionnaire to inform Ofgem of how the renewable proportion of the gas that is injected will be calculated, what meters are to be used at the facility and how the GCV and volume are to be measured accurately for the relevant quarterly period. For further information on the FMS questionnaire, please see the relevant section in Chapter Four, 'Ongoing fuel eligibility requirements', in Volume Two.

8.27 The propane measurement approach is also outlined in Chapter Nine, Volume Two.

8.28 Ofgem will agree an appropriate assurance regime with biomethane producers to allow them to verify that the procedures agreed between them and the biomethane producers have been followed.

Metering volume

8.29 In the FMS questionnaire you will be asked to provide information on the volume meters used at the injection point to measure the volume of gas entering the network. This information will include how many and what meters are being used at the injection point, and what the opening meter readings are on the day the application for registration is made.

8.30 Once registered, participants should use the volume meters that are used for the balancing and settlement and other industry transaction purposes for measurement of volume in the NIRHI.

Measuring GCV

8.31 The equipment used for measuring the GCV of the gas for regulatory purposes (which the Utility Regulator Northern Ireland would agree and approve of) should be used for calculating the weighted average GCV of the gas over the quarterly period for NIRHI purposes. This would be adjusted to standard temperature and pressure.

8.32 Where biomethane producers propose to blend their biomethane with natural gas prior to injection, Ofgem will review the measurement requirements outlined in the Network Entry Agreement to ensure that the measurement will be accurate.

8.33 Biomethane producers must deduct any heat used in the production of the biogas at the plant (where this has come from an external source, such as renewable or fossil fuel gas). Further details of this can be found in Volume Two.

Appendix 1

Meter Placement Examples

1. This Appendix provides examples of how the meter placement requirements outlined in Chapter 7 of this volume could apply in practice. These are illustrative examples only. Meter configurations which diverge from the arrangements described below may be permissible. However, participants may need to provide technical justification of how the requirements in Chapter 7 are met by their alternative approach.
2. The information in this Appendix is additional to that provided in Chapter 7; the eligibility and other metering requirements set out in that chapter still apply. Any 'heat' and 'steam' meters mentioned in this appendix must comply with all the relevant technical requirements set out in Chapter 7.
3. Further information on when and how to provide periodic data, i.e. meter readings and heat output figures to Ofgem, can be found in Chapter 3 of Volume 2. Information on how periodic data is used to calculate payments is in Chapter 5 of Volume 2.
4. In order to provide clarity on the meter positioning principles illustrated in this chapter, the diagrams displayed here are inherently 'simplified schematics', and do not illustrate all of the detailed specifications necessary to meet the requirements for a schematic submitted as part of an NIRHI application.
5. To give an indication of how some of the detail required for the schematic submitted for an application might be depicted, Example 8 (decentralised ineligible plant located on secondary heating circuits in separate buildings) has been provided with a key, a table of meter specifications and with buildings boundaries labelled and annotated.
6. The examples provided here show possible meter arrangements where:
 - i. An installation is classed as 'simple' for NIRHI metering purposes
 - ii. An installation is classed as 'complex' for NIRHI metering purposes and the heat transfer medium is water

- iii. An installation is classed as 'complex' for NIRHI metering purposes and the heat transfer medium is steam
- iv. Multiple plants comprise one installation and share a single meter
- v. Two eligible installations are connected in series (in this example, where one installation pre-heats the water that enters a second installation)
- vi. Hot water in a common storage tank is heated by both an ineligible plant (in this example, an electrical immersion heater) and an eligible installation
- vii. Reversible heat pumps generate both heating and cooling
- viii. Decentralised ineligible plant, (in this example, fossil fuel boilers), are located on secondary heating circuits in separate buildings

Example 1: Possible Meter Arrangement for an Installation that is Classed As 'Simple' for NIRHI Metering Purposes

- 7. Figure 1.1 shows an example where a biomass boiler (eligible installation) and a back-up gas-fired boiler (ineligible plant) supply hot water to a single office building which is then used for space heating purposes within that building only.
- 8. This installation is classed as 'simple' for NIRHI metering purposes because it does not deliver heat by steam and the heating system delivers heat only to eligible purposes within one building.
- 9. In this case, one heat meter (HRHI) is required to measure the heat generated by the installation as shown below. This takes information from the temperature sensors TRHI out and TRHI in and the flow meter FRHI.
- 10. The placement of the temperature sensors ensures that heat generated by the back-up gas-fired boiler (ineligible plant) is not included in the meter reading used for NIRHI payment purposes.
- 11. The participant needs to supply the cumulative meter reading in kWth as shown by the calculator/digital integrator to Ofgem in accordance with the timings and process set out in Chapter 3, 'Provision of Periodic Data – Heat Output Data and Supporting Meter Readings', of Volume 2 of this guidance.

13. In this example, although the installation does not deliver heat by steam, heat is used for an ineligible purpose as well as an eligible purpose. This means that the installation is classed as 'complex' for NIRHI metering purposes.
14. Following the approach for complex metering outlined in Chapter 7, three heat meters are required for NIRHI purposes. These need to be located to measure:
 - the heat generated by the biomass boiler (eligible installation) - Meter HRHI
 - the total heat generated by both the biomass boiler and the gas-fired boiler – Meter Htotal
 - the heat used for eligible purposes – Meter Heligible
15. Figure 1.2 shows a possible meter arrangement. In this case, a participant needs to supply the cumulative meter reading in kWhth as shown by the calculator/digital integrator for each meter to Ofgem in accordance with the timings and process set out in Chapter 3 of Volume 2.
16. This example schematic includes an illustration of the loop provided to recirculate heat directly to the boiler while bypassing the main heating circuit (sometimes referred to as the 'back end loop'). In line with Chapter 7 of Volume 1, the meter HNRHI has been located after the back end loop.
17. Denoting the cumulative meter reading at the start of a period by (1) and that at the end of the relevant period by (2), the participant would also need to use the cumulative meter readings to calculate and provide Ofgem with:
 - the total amount of renewable heat in kWhth generated by the installation during the relevant period = $HRHI(2) - HRHI(1)$
 - the total amount of heat from the heating system that was used for eligible purposes during the relevant period in kWhth = $Heligible(2) - Heligible(1)$, and the total amount of heat supplied to the heating system by both the eligible installation and the ineligible plant during the relevant period in kWhth = $Htotal(2) - Htotal(1)$

18. Further information about how these figures are used to determine the payment amount for the relevant period can be found in Chapter 5 of Volume 2.

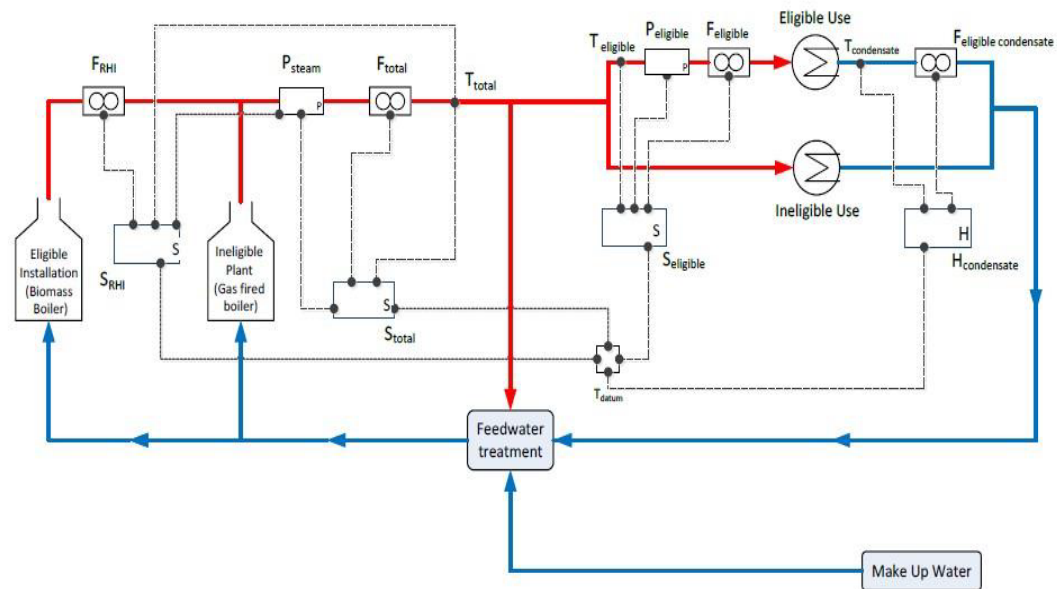

Key

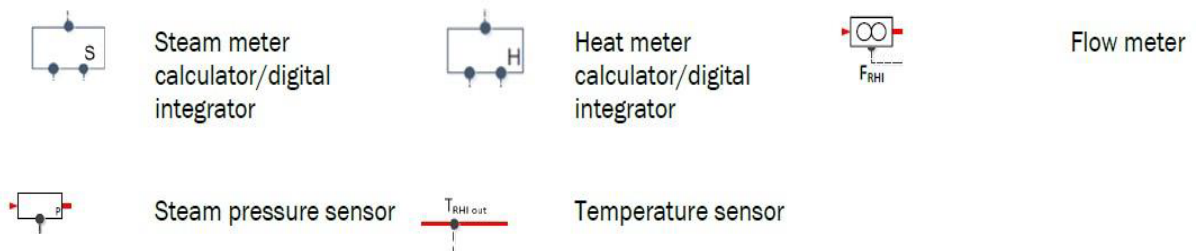

Figure 1.2: Illustration of possible metering arrangement for a complex installation where the heat transfer medium is a liquid. Note that the flow meter can be placed in either the flow or return pipe. Red lines denote the hot flow pipes, and blue lines indicate the cool return pipes.

Example 3: Possible meter arrangement for an installation that is classed as ‘complex’ for NIRHI metering purposes and the heat transfer medium is steam

19. Figure 1.3 shows an example where a biomass boiler and a back-up gas-fired boiler deliver steam both to an eligible purpose (carrying out a process) and an ineligible purpose (generating electricity). In this example, Ofgem assumes that condensate is returned from the eligible purpose in the form of hot water.

20. The installation is classed as 'complex' for NIRHI metering purposes because the heat transfer medium is steam and, in addition, heat is used for an ineligible purpose.
21. Steam generated by the installation is directed for feedwater treatment prior to the eligible use. This is classed as process internal heat and, therefore, is not eligible for NIRHI support. For further information about process internal heat, please see Chapter 6 of this volume.
22. In this example, the following meters would be required:
 - Steam meter located to measure the heat generated in the form of steam by the biomass boiler. The flow meter must be placed in the flow pipe, along with the pressure and temperature sensors. This is meter SRHI in the figure; this meter references the flow meter FRHI, the pressure sensor Psteam and the temperature sensor Ttotal (as well as the datum temperature Tdatum).
 - Steam meter located to measure the heat generated in the form of steam by both the biomass boiler and the gas-fired boiler. This is meter Stotal in the figure, which references the flow meter Ftotal, the pressure sensor Psteam and the temperature sensor Ttotal (as well as the datum temperature Tdatum).
 - Steam meter located to measure the heat in the form of steam delivered to the process (i.e. eligible purpose); this should not include any steam returned to the installation. This is meter Seligible in the figure, which references the flow meter Feligible, the pressure sensor Peligible and the temperature sensor Teligible (as well as the datum temperature Tdatum).
 - Heat meter located after the process (i.e. eligible purpose) to measure the energy in the condensate returned from the process. In this example, a temperature sensor must be located in the return pipe from the process, and the other temperature used in the calculation made by the calculator/digital integrator should be the datum temperature used by the steam meters, which will typically be 0 degrees. The flow meter must be positioned prior to the condensate entering any common pipework or vessels.

- This is meter Hcondensate in the figure, which references the flow meter Feligible condensate, and the temperature sensor Tcondensate (as well as the datum temperature Tdatum).
23. In this example, if lower grade steam had been returned from the eligible purpose, rather than hot water, the heat meter at bullet point 4 paragraph 21 would be replaced by another steam meter. This would require a separate pressure and temperature sensor to be added in the return pipe leaving the eligible purpose.
24. The steam meters SRHI and Stotal share a pressure and temperature sensor. Ofgem also assumes that the feedwater temperature is the same for both the eligible installation and the ineligible plant, so that measurement of the energy contained in the feedwater is not required.
25. The participant needs to provide cumulative meter readings in kWhth as shown by the calculator/digital integrator for each meter to Ofgem in accordance with the timings and process set out in Chapter 3 of Volume 2. Denoting the cumulative meter reading at the start of a period by (1) and that at the end of the relevant period by (2), the participant would also need to use the cumulative meter readings to calculate:
- The total amount of renewable heat generated by the installation during the relevant period in kWhth = $SRHI(2) - SRHI(1)$;
 - The total amount of heat from the heating system that was used for eligible purposes during the relevant period in kWhth = $Seligible(2) - Hcondensate(2) - [Seligible(1) - Hcondensate(1)]$;

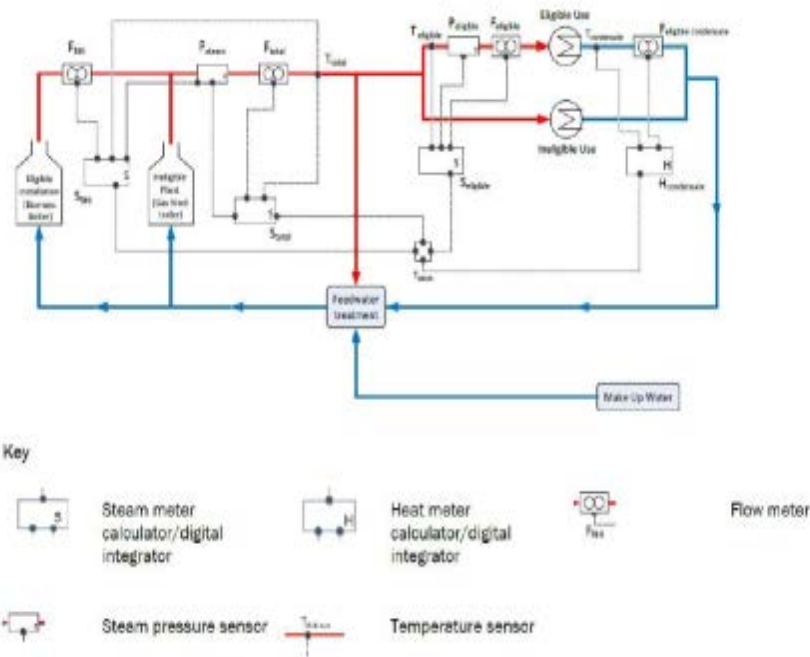

Figure 1.3: Illustration of possible steam meter (and component) placement for a heating system where an eligible biomass boiler and a gas-fired boiler deliver steam that is used for both an eligible and ineligible purpose. Condensate in the form of hot water is returned from the eligible purpose.

Example 4: Multiple plants comprising a single installation share a meter

26. Figure 1.4 shows an eligible installation comprised of three NIRHI-eligible biomass boilers supplying heat to a single heating system. In this example, the biomass boilers are considered as component plants which together make up one installation whose capacity is the sum of each individual boiler's capacity for NIRHI tariff purposes. They share the same tariff start and end dates.
27. The boilers supply heat in the form of hot water for space heating in one office block. This is therefore a simple installation for NIRHI metering purposes, and so only the heat generated by the eligible installation needs to be measured. In this case, it is possible for all three boilers to be metered using one meter, HRHI, providing that meter is placed:
- before the heat from the gas boiler enters the system, and
 - before any heat is supplied from the system to the eligible use (space heating in this case)

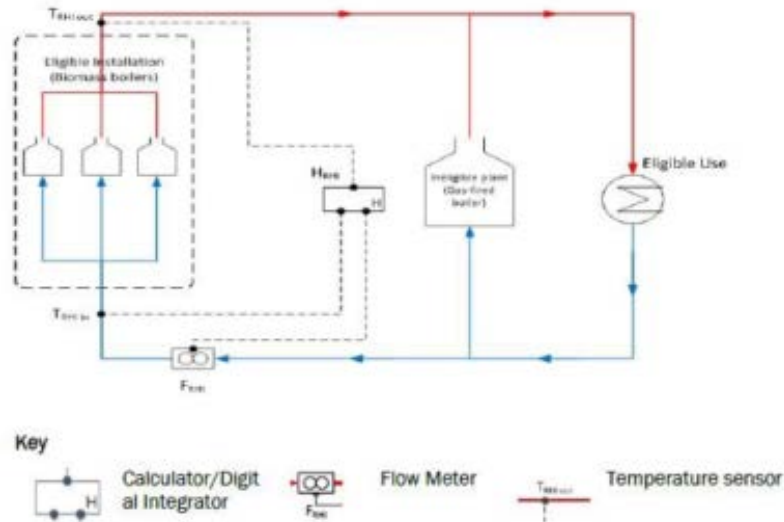

Figure 1.4: Illustrative example of a situation where a shared meter would be permitted. This installation would be classed as 'simple' for NIRHI metering purposes.

Example 5: Two eligible installations in series

28. In this example, a heat pump (eligible installation 1) pre-heats water delivered to a biomass boiler (eligible installation 2). Apart from this, this is the same system configuration as the heating system shown in Figure 1.2. Note that the owner or owners of the installation must apply for accreditation under separate NIRHI applications, and separate accreditation and ongoing obligations will be associated with each installation. Note that one implication of this is that separate schematic diagrams, appropriately annotated for each installation and indicating the plant for which NIRHI payments are being sought, should be submitted.
29. Both the heat pump and the biomass boiler are complex installations for NIRHI metering purposes, as the heating system of which they form part delivers heat to both an eligible purpose and an ineligible purpose. In this case, the following meters are required:

- i. A heat meter to measure the heat generated by each eligible installation. In this example, a shared meter is not allowed because the installations use different energy sources and will therefore have different tariff rates. However, heat meters may reference common components to provide them with the required information for their heat calculations. In this example, the heat meters determining the heat generated by the biomass boiler and the heat pump both reference the temperature sensor 'TRHI interim' and the flow meter 'FRHI'.

The hot water generated by the heat pump is measured by a heat meter (HHP), which uses the flow meter FRHI and temperature sensors TRHI and TRHI interim located in the heat pump's input pipe and in the output pipe prior to the hot water entering the biomass boiler respectively.

The hot water generated by the biomass boiler is also measured by a heat meter (HBB), which uses the flow meter FRHI and the temperature sensors TNRHI interim and TRHI out located in the biomass boiler's input pipe after the heat pump, and in the biomass boiler's output pipe prior to the hot water generated by the gas-fired boiler entering the heating system respectively.

- ii. A heat meter to measure the total heat generated by both the biomass boiler and the gas-fired boiler, H_{total} .
30. A heat meter to measure the heat used for eligible purposes, $H_{eligible}$.
 31. The participant would need to supply the cumulative meter reading in kWhth as shown by the calculator/digital integrator for each meter to Ofgem separately for each eligible installation (i.e. one set of periodic data would be submitted for the heat pump, and a separate set for the biomass boiler). For each installation, this information must be submitted in accordance with the timings and process set out in Chapter Three of Volume Two.
 32. Denoting the cumulative meter reading at the start of a period by (1) and that at the end of the relevant period by (2), and assuming that the periods over which data is submitted are the same for both installations, the participant would need to use the cumulative meter readings to calculate:

- The total amount of renewable heat generated by that installation during the relevant period = $HHP(2) - HHP(1)$ for the heat pump or $HBB(2) - HBB(1)$ for the biomass boiler
- The total amount of heat from the heating system that was used for eligible purposes during the relevant period = $H_{eligible}(2) - H_{eligible}(1)$, and
- The total amount of heat supplied to the heating system by both the eligible installations and the ineligible plant during the relevant period = $H_{total}(2) - H_{total}(1)$

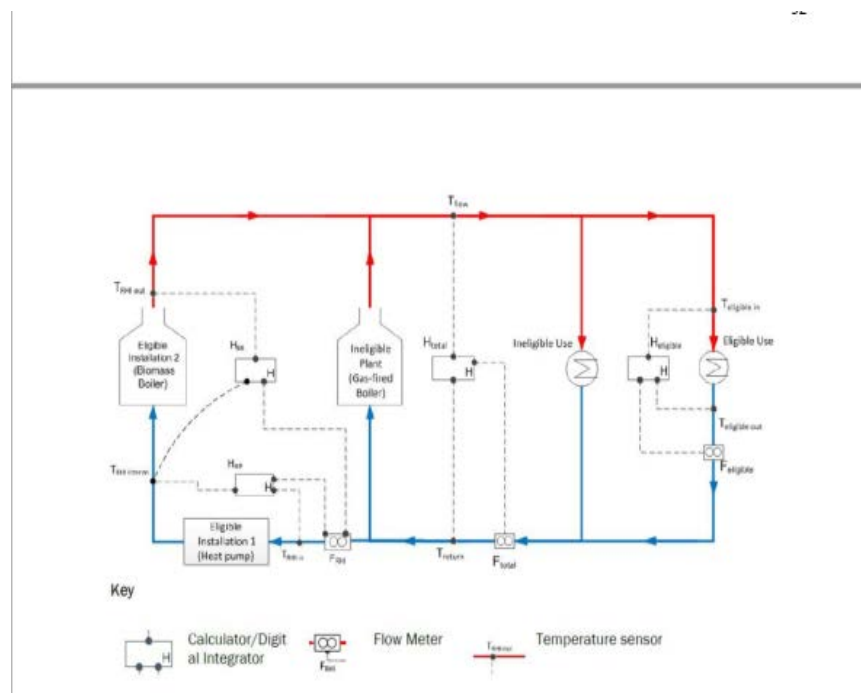

Figure 1.5: Illustration of permissible heat meter locations for a system where a heat pump (eligible installation 1) pre-heats water delivered to a biomass boiler (eligible installation 2).

Example 6: Hot water in a common storage tank is heated by both an ineligible plant and an eligible installation

33. It is common, particularly in systems where hot water is generated by solar thermal installations and heat pumps, for hot water storage tanks to have the facility for direct heating from an electrical immersion heater.

34. This is permissible for the NIRHI, providing no heat generated by the immersion heater is included in meter readings provided to Ofgem for NIRHI purposes. This means that temperature sensors must be placed to measure hot water generated prior to entering the storage tank where the hot water is mixed with water heated by the immersion heater. This may mean that temperature sensors TRHI in and TRHI out must be placed on the flow and return pipes from the eligible installation.
35. A permissible configuration is shown in Figure 1.6 below. This installation is classed as simple for NIRHI metering purposes, as heat is supplied by hot water to two eligible uses (hot water and space heating) in a single school building (and the installation does not deliver heat by steam). Therefore, one heat meter, HRHI, is required to measure the hot water generated by the solar thermal installation.
36. If the flow and return pipes from the solar thermal installation contain an ethylene glycol/water mixture or any other liquid, the Regulations require that the meter is appropriately calibrated for the properties of that liquid.

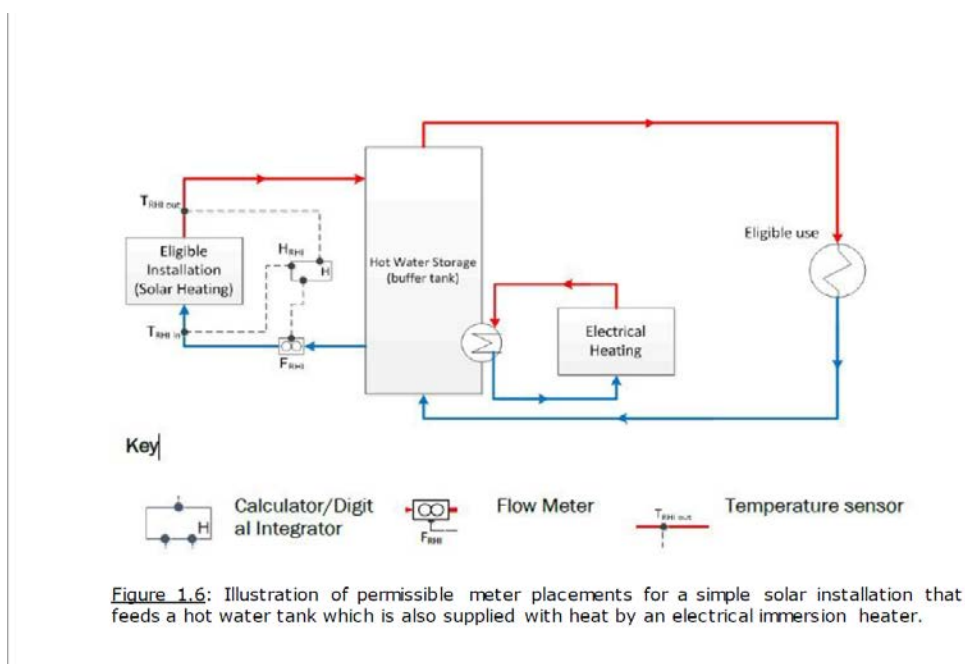

Figure 1.6: Illustration of permissible meter placements for a simple solar installation that feeds a hot water tank which is also supplied with heat by an electrical immersion heater.

Example 7: A reversible heat pump that generates both heating and cooling

37. Many heat pumps can operate in reverse to generate cooling in the warmer months. Such heat pumps are eligible for the NIRHI, but must be metered such that it is possible to calculate the cooling and heating generated separately. Only the heat generated by the heat pumps can be included in the meter readings submitted to Ofgem for NIRHI payment purposes.
38. Some heat pump installations will operate on a 'sliding header', as shown in Figure 1.7.
39. In this example, all heat is provided for hot water and space heating in one building, and so the installation is classed as simple for NIRHI metering purposes. The installation is comprised of four reversible ground source heat pumps which all have the same tariff start and end dates. Therefore, they may use a shared meter to measure the total heat generated by the installation, and so only one heat meter is required.
40. The flow meter can be placed in either the flow or return pipe. However, in this case the temperature sensors must be located in the flow and return pipes for the heating header to ensure that only heat that is eligible for the NIRHI is included in the meter readings provided for Ofgem for NIRHI payment purposes. If all the heat pumps in the installation are generating cooling, there should be no flow in the heating circuit as no eligible renewable heat is being generated.
41. Only heat recovered from the ground loops is eligible for NIRHI support. Any heat recovered from the cooling system and supplied to the heating system is ineligible for NIRHI purposes. This is because extracting heat from the cooling system is an efficiency measure; it is not heat from a renewable source. Any such heat must therefore be excluded from meter readings provided for NIRHI purposes, and meters must be positioned accordingly.

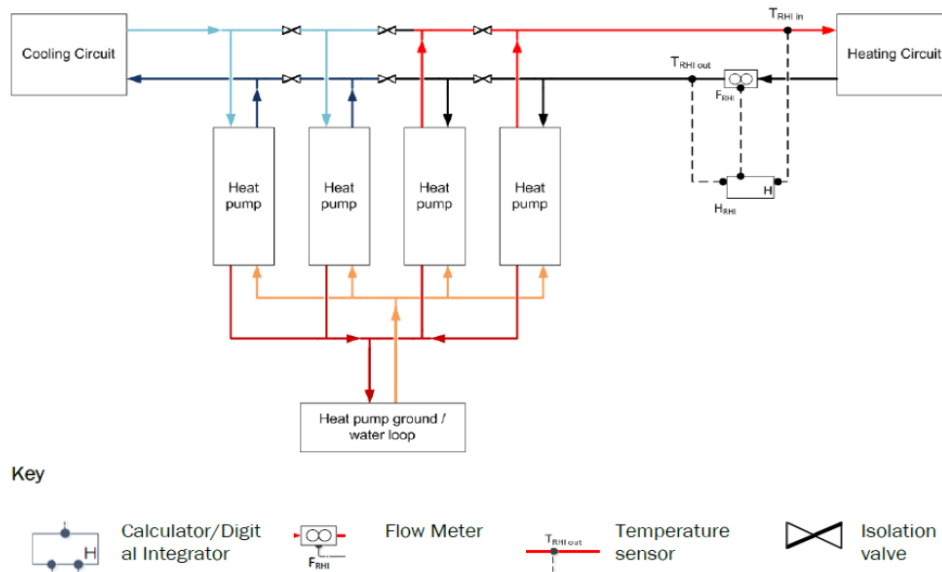

Figure 1.7: Illustration of permissible meter placement for a simple installation where four heat pumps deliver both heating cooling on a sliding header. In this case, two heat pumps are supplying the heating circuit, and the other two are supplying the cooling circuit.

Example 8: Possible meter arrangement for an installation with decentralised ineligible plant (in this example, fossil fuel boilers) located on secondary heating circuits in separate buildings

42. Figure 1.8 shows a heating system where a biomass boiler (eligible installation) supplies heat to two separate buildings. As heat is used in more than one building, the installation is classed as ‘complex’ for NIRHI metering purposes.
43. In this case, the heating system supplies heat that is used for space heating each building, such that all heat use within each building is for eligible purposes. Further information about what constitutes an eligible/ineligible purpose can be found in Chapter Six, ‘Heat uses’, of this Volume.
44. Each building has its own heat exchanger taking heat from the common heating circuit supplied by the installation, and a gas-fired boiler (ineligible plant) used as a back-up boiler and to provide top-up heat as required. In this case, although the installation does not deliver heat by steam, heat is used in more than one building. This means that the installation is classed as ‘complex’ for NIRHI metering purposes.
45. The Section titled ‘Alternative approach where separate heating circuits are fed by a common distribution system’ in Chapter 7 of this volume may apply in a

situation such as this. In such circumstances, we may consider proposals to measure the eligible heat delivered to this building using a single meter, where:

- Heat is supplied to a building via a heat exchanger, such that the building has a heat distribution system separate to the main distribution loop served by an installation, and
- There are no ineligible uses within the building, and
- The meter is capable of capturing only heat used for eligible purposes, i.e. it must not include any heat used for ineligible purposes, and
- It can be demonstrated that any heating plant(s) within the building make no contribution to providing heat for any use outside of the building which they serve

46. In this case, the term in the tariff calculation formula for heat generated by all plants supplying heat to the same heating system of which the installation forms part, would not include heat generated by plants within the building. For more details on how payments are calculated, see Chapter Five of Volume Two.

47. Assuming the above conditions are met, three heat meters are required for NIRHI purposes. These need to be located to measure:

- the heat generated by the biomass boiler (eligible installation) – Meter HRHI
- the total heat used for eligible purposes by the ‘main building’ – HA
- the total heat used for eligible purposes by the ‘outbuilding’ – HB

48. Figure 1.8 shows a possible meter arrangement. In this case, a participant would need to supply the cumulative meter reading in kWhth as shown by the calculator/digital integrator for each meter to Ofgem in accordance with the timings and process set out in Chapter Three of Volume Two.

49. Denoting the cumulative meter reading at the start of a period by (1) and that at the end of the relevant period by (2), the participant would also need to use the cumulative meter readings to calculate (and provide Ofgem with):

- the total amount of renewable heat in kWhth generated by the installation during the relevant period = $HRHI(2) - HRHI(1)$
- the total amount of heat from the heating system that was used for eligible purposes during the relevant period in kWhth = $(HA(2) - HA(1)) + (HB(2) - HB(1))$, and
- the total amount of heat supplied to the heating system by both the eligible installation and the ineligible plant during the relevant period in kWhth = $HRHI(2) - HRHI(1)$

50. Note that in this case, the total heat supplied to the system is equal to that supplied by the eligible installation, as there are no other plants supplying heat to the heating system. As these quantities are the same, the meter HRHI will provide appropriate readings for both “heat generated by the NIRHI installation” and “total heat generated on the system” in the complex formula for payment. For more details on how payments are calculated, see Chapter Five of Volume Two.

Note that although these quantities are the same value, and this may in general result in a simplification of the tariff payment formula, it will still be necessary to provide a meter reading in order to meet the ongoing obligations of the scheme.

51. Further information about how these figures are used to determine the payment amount for the relevant period can be found in Chapter Five of Volume Two.

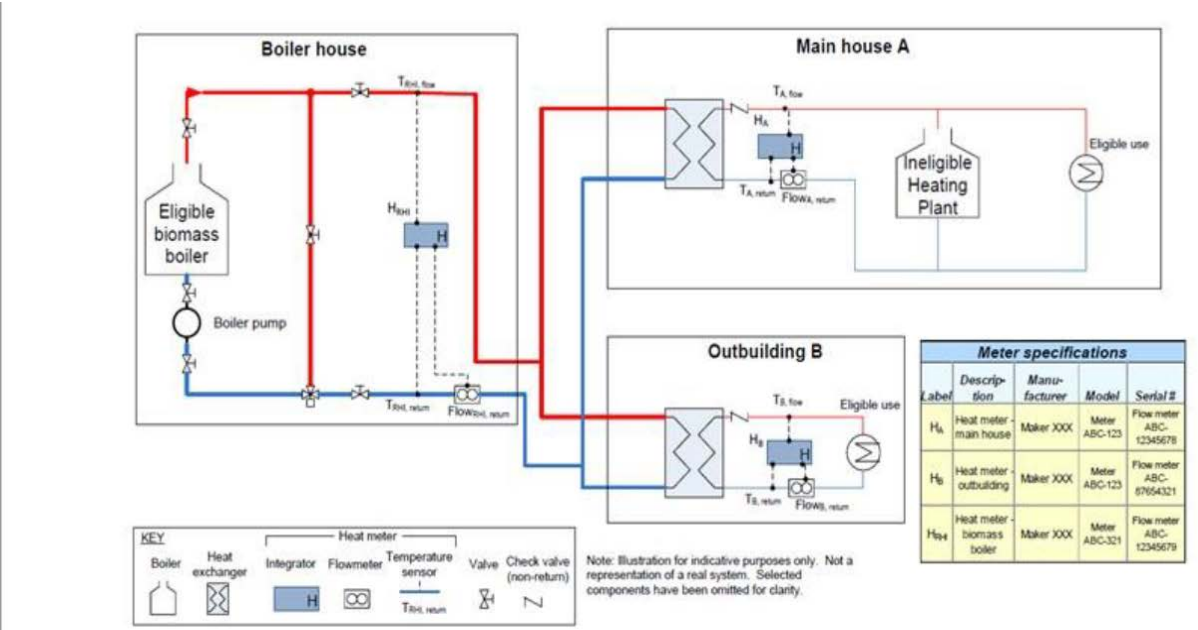

Figure 1.8: Illustration of possible metering arrangement for a complex installation where decentralised ineligible plants (in this example, fossil fuel boilers) are located on secondary heating circuits in separate buildings. Note that the flow meter can be placed in either the flow or return pipe. Red lines denote the hot flow pipes, and blue lines indicate the cool return pipes. This schematic has been annotated with a key, a table of meter specifications, and building names/boundaries, as discussed in Section 1.4 of this Appendix.

Appendix 2

Municipal Waste Lists

As noted in Chapter Five of this volume, there are two tables below that concern the list of wastes.

Table 1: Examples of the categories of wastes that are considered to be classified as municipal waste (this list is not exhaustive)

Categories of Wastes	Codes of Wastes classed as municipal waste	Examples of wastes classed as municipal waste (list not exhaustive)
Municipal wastes (household waste and similar commercial, industrial and institutional waste) including separately collected fractions	All codes	<ul style="list-style-type: none"> • Paper and cardboard • Biodegradable kitchen and canteen waste • Glass • Textiles • Plastics • Metals • Gardens and park waste
Wastes from waste management facilities, off-site waste water treatment plants and the preparation of water intended for human consumption and water for industrial use	Code 19 05 – Wastes from aerobic treatment of solid wastes	<ul style="list-style-type: none"> • Non-composted fraction of municipal and similar wastes • Non-composted fraction of animal and vegetable waste
	Code 19 06 – Wastes from anaerobic treatment of waste	<ul style="list-style-type: none"> • Digestate from anaerobic treatment of municipal waste • Digestate from anaerobic treatment of animal and vegetable waste
	Code 19 12 – Wastes from the mechanical treatment of waste (for example sorting, crushing, compacting, pelleting) not otherwise specified	<ul style="list-style-type: none"> • Paper and cardboard • Ferrous metal • Wood • Combustible waste (refuse derived fuel)
Waste packaging; absorbents, wiping cloths, filter materials and protective clothing not otherwise specified	Code 15 01 01	<ul style="list-style-type: none"> • Paper and cardboard packaging
	Codes 15 01 05 – 15 01 09 Code 15 01 02	<ul style="list-style-type: none"> • Plastic packaging • Textile packaging

Table 2: Examples of the categories of wastes that it is considered are not to be classed as municipal waste (this list is not exhaustive)

Categories of Wastes (list not exhaustive)	Example codes not being classed as municipal waste	Examples of wastes <u>not</u> classed as municipal waste (list not exhaustive)
Wastes from agriculture, horticulture, aquaculture, forestry, hunting and fishing, food preparation and processing	Code 02 01 – Wastes from agriculture, horticulture, aquaculture, forestry, hunting and fishing	<ul style="list-style-type: none"> • Sludge from washing and cleaning • Wastes from forestry
Wastes from wood processing and the production of panels and furniture, pulp, paper and cardboard	Code 03 01 – Wastes from wood processing and the production of panels and furniture	<ul style="list-style-type: none"> • Sawdust, shavings, wood, particle board and veneer
Waste packaging; absorbents, wiping cloths, filter materials and protective clothing not otherwise specified	Code 15 01 03	<ul style="list-style-type: none"> • Wooden packaging
Construction and demolition wastes (including excavated soil from contaminated sites)	Code 17 01 – Concrete, bricks, tiles and ceramics	<ul style="list-style-type: none"> • Concrete • Bricks • Tiles and ceramics
Wastes from waste management facilities, off-site waste water treatment plants and the preparation of water intended for human consumption and water for industrial use	Code 19 07 – landfill leachate	<ul style="list-style-type: none"> • Landfill leachate

Glossary of RHI Terms

A
ACCREDITATION
In order to receive support under the NIRHI, an eligible installation will have to be accredited by Ofgem. Accreditation (which is defined in the Regulations) is the term used to denote admission to the NIRHI once it has been determined that the installation meets the eligibility criteria of the scheme and that the application for accreditation is properly made.
ADDITIONAL NIRHI CAPACITY
Additional NIRHI capacity, which is defined in the Regulations, means a plant which is first commissioned after the date on which an NIRHI installation was first commissioned, uses the same source of energy and technology as the original plant and supplies heat to the same heating system.
ADDITIONAL PLANT
Additional plant means a heat generating plant which uses a different technology or source of energy to an existing accredited NIRHI installation but is connected to the same heating system as the accredited NIRHI installation.
ANCILLARY FOSSIL FUEL
Ancillary fossil fuel refers to the small amounts of fossil fuel necessary for the effective operation of the installation.
ANNUAL DECLARATION
The annual declaration is a confirmation that must be signed by the Authorised Signatory to confirm that the accredited NIRHI installation/registered biomethane producer has met the eligibility criteria and ongoing obligations of the scheme for the previous 12 months.
AUTHORISED SIGNATORY
An Authorised Signatory is a person who is authorised to open and use an account with the Ofgem NIRHI website or provide information by post, submit periodic data and complete the NIRHI annual declaration.
B
BIOENERGY
This term is used as shorthand for any of the following technologies: solid biomass, solid biomass from municipal waste, biogas, biomethane.

C

COMMISSIONED

This means, in relation to an eligible installation, that all tests required by industry standards for the installation to be able to deliver heat for the purpose for which it was installed, have been completed. For a legal definition, please see the Regulations.

COMMON HEADER

This is the main pipe to which plants supply heat, and from which heat uses are supplied. A heating system may have multiple common headers.

COMPLEX INSTALLATION

A complex installation is any installation that is not considered simple.

F

FLOW PIPE

The pipe carrying the hot water flow leaving an installation or heat use is commonly referred to as the flow pipe.

FUEL MEASUREMENT AND SAMPLING (FMS)

The term 'fuel measurement and sampling' (FMS) refers to the way in which the renewable biomass proportions of input fuels are determined. By 'measurement', Ofgem means determining the amount or quantity of a fuel (for example in tonnes or cubic meters). By 'sampling', Ofgem means taking small sample amounts of fuel and testing them to determine specific properties such as their GCV.

I

INSTALLATION CAPACITY

The installation capacity is defined in the Regulations as the 'total installed peak heat output capacity of a plant' (which includes the 'total installed peak heat output capacity' of a single plant (installation) made up of two or more component plants).

K

KILOWATTS (kW)

A kilowatt is a measure of power i.e. the rate at which energy is transferred or converted. A kilowatt is equal to 1 kilojoule of energy transferred/converted each second.

KILOWATT-HOURS (kWh)

A kilowatt-hour is the measure of energy transferred or converted over a period of time. A kilowatt-hour is equal to the amount of energy generated by an installation with a power capacity of 1kW in an hour or an installation with a power capacity of 2kW in a half-hour etc.

N**NOMINATED INDIVIDUAL**

An individual within an organisation nominated to act on the organisation's behalf in relation to the NIRHI.

O**ONGOING OBLIGATIONS**

Ongoing obligations refer to the obligations that need to be met to remain accredited or registered to the scheme. The term is defined in the Regulations.

P**PARTICIPANT**

A participant is defined in the Regulations as either the owner of an accredited NIRHI installation, a representative owner or a producer of biomethane who has registered with the Authority to receive the NIRHI. In practice this means that once the owner or representative owner of an eligible installation or a biomethane producer receives accreditation or registration respectively to the NIRHI scheme, they will be referred to as a participant in the NIRHI scheme.

PERIODIC SUPPORT PAYMENTS

NIRHI support will be delivered to participants in the form of quarterly 'periodic support payments', the term being defined in the Regulations.

PERIODIC DATA

Periodic data is the information participants need to submit on a regular basis as an ongoing obligation, and in order for Ofgem to calculate the appropriate payment.

R**RENEWABLE HEAT INCENTIVE**

The Renewable Heat Incentive is a DfE scheme programme designed to provide long-term financial support to renewable heat installations to encourage the uptake of renewable heat.

REPRESENTATIVE OWNER

Where there is more than one owner of an accredited NIRHI installation, the owner with the authority to act on behalf of all owners is referred to as the representative owner.

RETURN PIPE

The pipe carrying the cool liquid flow returning from an installation or heat use is commonly referred to as the return pipe.

S**SCHEMATIC DIAGRAM**

The schematic diagram is an illustration of the installation and heating system for which NIRHI accreditation is being applied for.

SIMPLE INSTALLATION

A simple installation is an installation which does not deliver heat by steam, does not supply heat to an ineligible purpose, and where all the uses of the heat produced are in the same building as the heat generating plant.

T**THERMOCOUPLE**

Electronic sensor for measuring the temperature of pipework at a given position.